

SOUTHERN AVIONICS COMPANY
MANUFACTURERS OF LOW FREQUENCY RADIOBEACONS AND ASSOCIATED PRODUCTS



MODEL SS-800AVS

NON-DIRECTIONAL RADIOBEACON

MANUAL #80AVS-90-2



SOUTHERN AVIONICS COMPANY

MANUFACTURERS OF LOW FREQUENCY RADIOBEACONS AND ASSOCIATED PRODUCTS

5000 BELMONT, P.O. BOX 5345 / BEAUMONT, TEXAS 77726-5345 USA
TELEPHONE: (409)842-1717; FAX: (409)842-2987; CABLE: SAC; TELEX: 77-9450

LIMITED WARRANTY

SOUTHERN AVIONICS COMPANY (hereinafter called COMPANY) warrants to the original purchaser for a period of one year from the date of delivery to the original purchaser, that the goods sold pursuant to this COMPANY invoice were at the time of the delivery, free from defects resulting from faulty material or workmanship. THIS LIMITED WARRANTY IS IN LIEU OF ALL OTHER REPRESENTATIONS AND EXPRESS WARRANTIES. This warranty is made for the benefit of the initial purchaser only and is not made for the benefit of any party other than initial purchaser. This warranty applies only if the goods are submitted to normal use and service and does not apply if the goods are misused.

ALL IMPLIED WARRANTIES EXISTING UNDER THE LAW ARE HEREBY EXPRESSLY NEGATED; PARTICULARLY, COMPANY HEREBY NEGATES AND DISCLAIMS THE IMPLIED WARRANTY OF MERCHANTABILITY AND IMPLIED WARRANTY OF FITNESS FOR A PARTICULAR PURPOSE.

If Purchaser believes that these goods do not comply with the express warranty stated above or any existing and applicable implied warranty which under the law cannot be disclaimed or negated as provided above, then purchaser may request that COMPANY inspect such goods by mailing, within sixty (60) days after purchaser knows or should have known that the goods allegedly do not conform with the warranty, postage prepaid, to COMPANY, P.O. Box 5345, 5000 Belmont, Beaumont, Texas, 77726 Attention: President, a writing specifying (a) purchaser's name, address, and telephone number, (b) date of purchase, (c) COMPANY distributor or location from which the goods were purchased, (d) location of the goods in question (or include the goods in question with the notice), and (e) a brief description of the alleged nonconformity with the warranty. If the goods are covered by, and do not conform with, the warranty, COMPANY will repair or replace F.O.B. point of manufacture any such goods; but in no event will COMPANY be obligated or required to remove the non-conforming goods from their place of installation or to install the replacement goods. All replacement goods are warranted to the extent provided herein for the remaining term of this warranty.

In the event purchaser chooses to commence an action for breach of warranty or breach of contract arising out of the sale of the goods pursuant to this invoice, the purchaser must commence such action within one year after the cause of action accrues.

THE REMEDY PROVIDED HEREIN SHALL BE THE SOLE AND EXCLUSIVE REMEDY FOR BREACH OF THIS WARRANTY, FOR ANY BREACH OF ANY IMPLIED WARRANTY EXISTING AND APPLICABLE UNDER THE LAW (TO THE EXTENT THAT ANY SUCH WARRANTY HAS NOT BEEN SUCCESSFULLY NEGATED AND DISCLAIMED HEREINABOVE), AND FOR ANY ACT OF NEGLIGENCE OR ANY OTHER TORTIOUS ACT COMMITTED BY COMPANY, AND IN NO EVENT SHALL THE COMPANY BE LIABLE TO PURCHASER OR ANY THIRD PARTY FOR ANY INCIDENTAL, CONSEQUENTIAL OR SPECIAL DAMAGES RESULTING FROM ANY DEFECT IN THE GOODS OR ANY FAILURE OF THE GOODS TO CONFORM WITH THIS WARRANTY OR ANY IMPLIED WARRANTY EXISTING AND APPLICABLE UNDER THE LAW (TO THE EXTENT THAT ANY SUCH IMPLIED WARRANTY HAS NOT BEEN SUCCESSFULLY NEGATED AND DISCLAIMED HEREINABOVE).

Table of Contents

1	INTRODUCTION	11
1.1	General Description: SS-800AVS	1
1.2	Specifications: SS-800AVS	3
1.3	General Description: PC-1000B	7
1.4	Specifications: PC-1000B	9
2	THEORY OF OPERATION, RADIOBEACON	11
2.1	Functional Description: SS-800AVS	11
2.2	Detailed Circuit Analysis: SS-800AVS	13
2.2.1	Synthesizer PWB:	13
2.2.2	AM Oscillator PWB	17
2.2.3	Audio PWB (Optional)	21
2.2.4	Keyer	25
2.2.4.1	Letter PWB	25
2.2.4.2	Number PWB	26
2.2.4.3	AM Recycle PWB	26
2.2.5	Driver PWB	35
2.2.6	Final Stage	39
2.2.7	Power Supply	41
2.2.8	Battery System	45
2.2.9	AM Auto Shutdown PWB	49
2.2.10	Power Switch PWB Assembly	53
2.2.11	Metering Circuit	57
2.2.12	Reset SSC PWB	61
3	THEORY OF OPERATION, ANTENNA COUPLER	69
3.1	FUNCTIONAL DESCRIPTION: PC-1000B	69
3.1.1	Impedance Transformer	69
3.1.2	Tuner	69
3.1.3	Autotune	69
3.1.4	Antenna Current/Tuning Meter	69
3.2	DETAILED CIRCUIT ANALYSIS: PC-1000B	71
3.2.1	Impedance Transformers:	71
3.2.2	Tuner:	71
3.2.3	Autotune	73
3.2.4	Antenna Current/Tuning Meter	77
4	ANTENNAS	81
4.1	Mast Antenna	81
4.2	"H" Antenna	82
4.3	50-Foot Guyed Mast Antenna	82
4.4	Symmetrical "T" Antenna	83
5	INSTALLATION AND OPERATION	85
5.1	Transmitter Installation	85
5.2	Coupler Setup	87

5.3	Synthesizer Adjustment	95
5.4	Antenna Tune-Up	99
5.5	Audio Mode Selection	103
5.6	Tone Modulation Adjustments	104
5.7	Transmitter Adjustments	105
5.7.1	Autoshutdown and Audio Alignment	105
5.7.2	Autoshutdown Adjustment - Nonvoice System	106
5.7.3	Automatic Shutdown Test	106
5.7.4	Final	107
6	MAINTENANCE	109
6.1	Cautions and Test Equipment List	109
6.1.1	General Precautions	109
6.1.2	Specific Precautions	109
6.1.3	Test Equipment List	109
6.1.3.1	Field Service or Checkout	110
6.1.3.2	System Alignment and Calibration	110
6.2	System Alignment and Calibration	111
6.2.1	AM Oscillator PWB	111
6.2.1.1	Preliminary	111
6.2.1.2	Frequency and Modulation Adjustment	111
6.2.2	Audio PWB Adjustment	112
6.2.3	Antenna System Changes	112
6.2.4	Battery Charger Float Voltage Adjustment	113
6.3	Preventive Maintenance	115
6.3.1	Maintenance Log	115
6.4	Corrective Maintenance	117
6.4.1	Index To Testpoints	117
7	PARTS LIST	127
8	MODIFICATIONS	163

Table of Figures

Transmitter Enclosure Dimensions	2
Coupler Enclosure Dimensions	8
Block Diagram	12
Synthesizer PWB Schematic	14
Synthesizer PWB Assembly	15
Synthesizer Programming PWB Assembly	16
AM Oscillator PWB Schematic	18
AM Oscillator PWB Assembly	19
Audio PWB Schematic	22
Audio PWB Assembly	23
Letter PWB Schematic	29
Letter PWB Assembly	30
Number PWB Schematic	31
Number PWB Assembly	32
AM Recycle PWB Schematic	33
AM Recycle PWB Assembly	34
Driver PWB Schematic	36
Driver PWB Assembly	37
Final Stage Schematic	40
50 V Power Supply Schematic	42
50 Volt Power Supply	43
SSC Battery Standby Schematic	46
SSC Battery Standby Assembly	47
AM Auto Shutdown PWB Schematic	50
AM Auto Shutdown PWB Assembly	51
Power Switch PWB Schematic	54
Power Switch PWB Assembly	55
Meter PWB Schematic	58
Meter PWB Assembly	59
Meter Bracket Assembly	60
Auto Shutdown Reset PWB Schematic	63
Reset SSC PWB Assembly	64
Transmitter Schematic	66
Transmitter Diagram	68
PC-1000 Block Diagram	70
PC-1000B Antenna Coupler Schematic	72
Autotune Motor Drive PWB Schematic	75
Autotune Motor Drive Pwb Assembly	76
Antenna Current/Tuning Meter Pwb Schchematic	78
Antenna Current/Tuning Meter PWB Assembly	79
Antenna Reactance	84
Antenna Coupler Cable Connections	88
Impedance Transformer Taps	89
Mast Antenna and PC-1000 Mast Tuned for 190-415 KHz	90
Mast Antenna and PC-1000 Mast Tuned for 415-625 KHz	91
50 Foot Guyed Mast and PC-1000	92

Symmetrical "T" Antenna and PC-1000 93
Synthesizer Bands 97
Control and Testpoin Positions 98

1 INTRODUCTION

1.1 General Description: SS-800AVS

This non-directional beacon is a dual carrier transmitter with an adjustable output power of up to 100 watts. This is the power of a single carrier. The second carrier is added to the first during modulation. This produces a signal with an AM type waveform and an SSB bandwidth. The bandwidth of a dual carrier emission is the same as the audio tone (either 1020 Hz or 400 Hz).

The transmitter operates on 115/230 VAC, 50/60 Hz or 48 VDC.

An automatic shutdown circuit is included that automatically shuts down the transmitter if power falls below an adjustable level, if the ident signal fails, or if extreme distortion is present. When a dual system is used, the shutdown signal is used to transfer to the standby transmitter.

A current and voltage limiter protects the transmitter from line surges or voltage and current surges in the final due to accidental shorts or improper tuning.

The transmitter is in a rain-tight enclosure that permits it to be mounted out-of-doors at the base of the antenna.

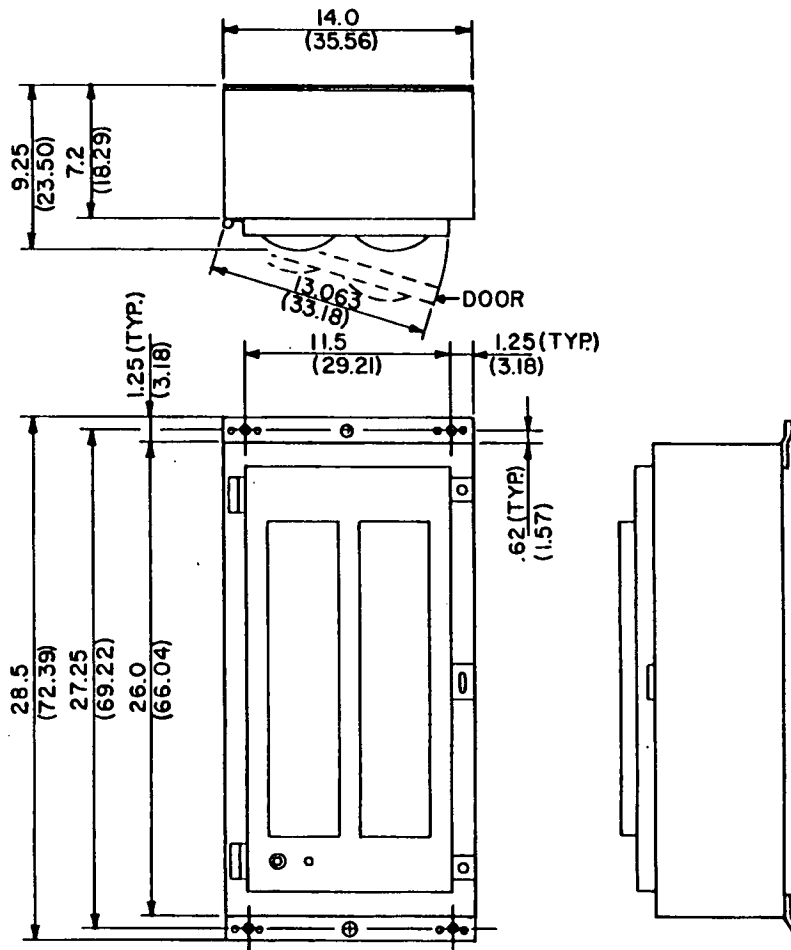

FRONT VIEW

SIDE VIEW

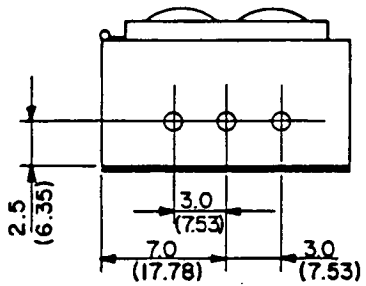

BOTTOM VIEW
CONDUIT ENTRANCE LOCATIONS

- NOTES: 1. IN/OUT CONNECTIONS ARE MADE WITH FLEXIBLE CONDUIT THROUGH THE BOTTOM.
 2. THIS DRAWING NO. 1471 REV. B.
 3. DIMENSIONS IN INCHES (CM).
 4. NET. WT. 45 LBS. (20KG).

TRANSMITTER ENCLOSURE DIMENSIONS

1.2 Specifications: SS-800AVS

QUALIFICATIONS: Meets applicable requirements of the Federal Aviation Administration (FAA), Federal Communications Commission (FCC), and International Civil Aviation Organization (ICAO).

FREQUENCY: 190-625 KHz.

FREQUENCY CONTROL AND STABILITY: Crystal controlled synthesizer. Rotary dial selection in KHz steps, at integral or half integral KHz; stability better than 0.005% (-50° to +70°C). Programming boards are used to cover 190 to 625 KHz in bands of 190-250 KHz, 240-340 KHz, 320-415 KHz, and 415-625 KHz.

TYPE OF EMISSION: AO/A2, A3, AO/A2/A3; Keyed code tone modulation of an RF carrier. Optional voice modulation of RF carrier, simultaneous voice and code tone modulation of an RF carrier, non-simultaneous voice and code tone modulation of an RF carrier.

POWER OUTPUT: 20 to 100 watts continuously adjustable into a 50 ohm load. Power increases during modulation.

MODULATION: Keyed 400 Hz or 1020 Hz tone, International Morse Code, any combination of up to three letters or numerals, and/or optional voice modulation. Modulation percentage adjustable from 0-100 percent. Code modulation percent to 100% with voice signal absent or to 20% with voice signal present.

BANDWIDTH: 800 or 2040 Hz depending on tone frequency. Up to 6000 Hz for voice transmission.

HARMONIC DISTORTION: All harmonics are more than 63 dB below the 100 watt carrier, measured at a dummy antenna simulating a SAC Mast Antenna.

CIRCUIT PROTECTION: Lightning protection on power line and antenna connection. Circuit breaker in power line. Fuse in power line to final circuit. Zener protection and fuses on transistors in final circuit. Special current and voltage limiting circuit on 50V DC line.

METERING: RF output power, DC current in one of the final transistors, DC voltmeter, reflected power.

WORKING CONDITIONS: Continuous unattended operation in the following environments: Ambient temperature, -50° to +70°C; Relative humidity, 0-100%; High salinity as encountered in offshore conditions.

AUTOMATIC SHUTDOWN: Transmitter shuts down with loss of tone or continuous tone, or extreme distortion due to a change in load, or when power falls below a preset value.

AUDIO LINE INPUT: Balanced, 600 ohms $\pm 20\%$, -17 dBm nominal. Will accept -28 dBm to +5 dBm. (0 dBm=1 mW into 600 ohms). Audio line direct current shall not exceed 3 mA DC.

TRANSMITTER AUDIO LINE CONTROL CIRCUITS:

Squelch Allows line input signals to pass through to the modulator when the line signals exceed the squelch trip point. Controls code signal modulation level (to 95% with line signal absent, to 20% with line signal present). Operates with fast attack, slow decay characteristics. Squelch level adjustable from -30 dBm to +5 dBm.

AGC Maintains a constant average modulation level for line input signals. At maximum sensitivity, AGC stage will accept input levels of -28 dBm to +5 dBm without modulation percent change. Attack and decay times adjusted for voice type line signals.

Over Modulation Control

Limits modulation of carrier to 100% on severe overload of AGC circuits. Allows clipping of voice signals to increase average modulation percentage.

INPUT POWER: 115/230 VAC $\pm 20\%$, 50/60 Hz, 420 VA maximum, or 48 VDC, 5.5 amperes maximum.

EMERGENCY BATTERY SUPPLY (Optional): When emergency batteries are used, the optional Battery Standby System automatically keeps the batteries charged when AC power is available, and automatically switches to batteries on loss of AC power. Four 105 AH deep cycle (marine type) 12V batteries, such as Gould AP-105, will operate the transmitter for approximately 13 hours.

INSTALLATION REQUIREMENTS: The transmitter is supplied in a weatherproof enclosure. The transmitter and the antenna coupler are suitable for pole mounting out-of-doors.

SPECIFICATIONS FOR ELECTRICAL CONNECTION BETWEEN AUDIO SOURCE AND TRANSMITTER SITE: For short distances of up to 300 feet, direct connection of the audio drive source to the transmitter audio input may be made through a twisted wire pair or 600 ohm open wire pair. For greater distances, equalization of the audio line may be required to prevent loss of the higher audio frequencies.

For installation requiring the use of leased telephone circuits from the audio source to the transmitter site, the following should be specified when ordering the circuit:

1. Line impedance 600 ohms, balanced, audio only.
2. Line equalization for frequencies 400 Hz to 2800 Hz.
3. Maximum line input +5 dBm.
4. Normal equipment input -8 dBm.
5. Maximum line loss -12 dBm.
6. If DC current is present on the telephone pair, the DC current shall be isolated from the transmitter audio input. Maximum DC component to the transmitter audio input is 3 mA DC.
7. Line coupling devices installed at the transmitter shall not be such that RF energy emitted from the transmitting antenna will be demodulated in the coupling device with the demodulated audio appearing as an audio input to the transmitter. Coupling devices containing varistors should not be used unless RF energy is bypassed.

1.3 General Description: PC-1000B

The antenna coupler couples the 50 ohm output of the transmitter to a SAC Mast Antenna, "T" Antenna, "H" Antenna, or Guyed Mast Antenna.

The coupler consists of an impedance transformer, a large tapped coil with a rotatable shorted ring, and a meter. The shorted ring is driven by a motor that is controlled by the Autotune Motor Drive PWB in the coupler.

The coupler is mounted in a metal enclosure with dimensions 22.5" (57 cm) wide, 21.5" (55 cm) deep, 26.5" (67 cm) high and is designed for outdoor mounting.

The optional coupler power supply furnishes 50V DC for operation of the autotuning system and metering circuits. The power supply operates from 115/230 VAC, 50-500 Hz, and is required when the coupler is used with transmitters not manufactured by Southern Avionics Company.

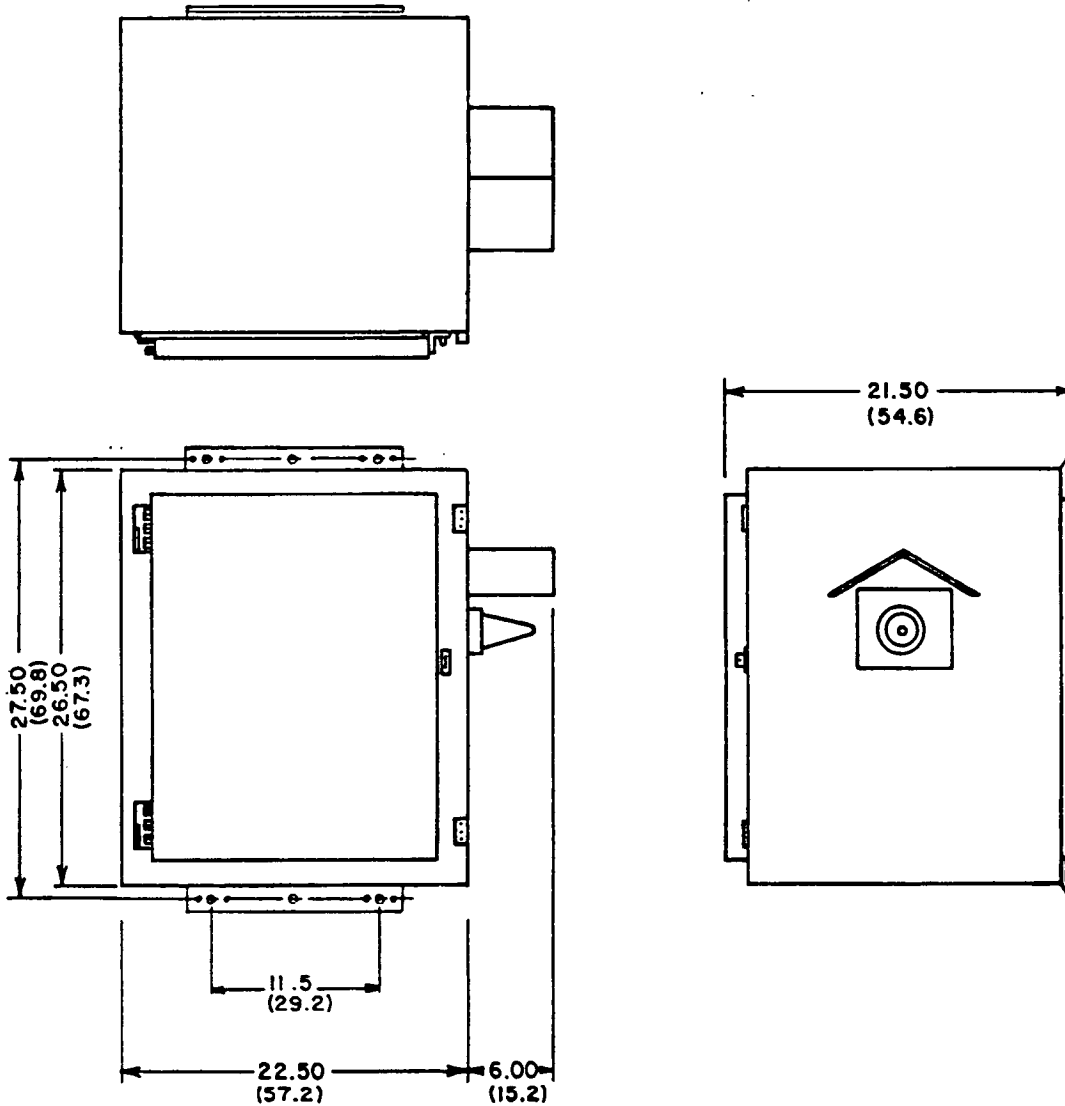

- NOTES: 1. IN/OUT CONNECTIONS ARE MADE WITH FLEXIBLE CONDUIT THROUGH THE BOTTOM.
 2. THIS DWG NO. 2716
 3. DIMENSIONS IN INCHES (CM).
 4. NET WT. 46 LBS. 21 KS.
 5. MOUNTING—CENTER LINE
 11.5 CENTERS (DEPICTED)
 TOWER LEG MOUNT 11.25" CENTERS.

COUPLER ENCLOSURE DIMENSIONS

1.4 Specifications: PC-1000B

INPUT IMPEDANCE: 50 ohms.

LOAD IMPEDANCE: 2 to 25 ohms resistance, 200 to 1500 pF capacitance.

FREQUENCY: 190 - 625 KHz with a 200 to 1500 pF load.

POWER INPUT: Up to 500 watts peak, 200 watts continuous.

METERING: Antenna current and tuning. Single meter with a four position switch; OFF, TUNE, HIGH, LOW. A reflected power measurement is used for a tuning indication.

TUNING: Large coil with coarse taps and fine taps and a rotatable shorted ring. The coarse tap is selected with a solder connection behind a removable panel. The fine tap is selected with a switch. The autotune system drives the shorted ring for exact tuning.

LIGHTNING PROTECTION: Lightning gap at the antenna terminal. Special passive circuit that protects the transmitter final amplifier from lightning transients.

WORKING CONDITION: Ambient temperature, -50°C to 70°C; relative humidity 0 to 100%; high salinity as encountered in offshore conditions. The antenna coupler is designed for outdoor mounting at the base of the antenna.

POWER REQUIREMENTS: 48V DC, 500 mA, supplied to coupler from Southern Avionics transmitters. Optional 115/230 VAC, 50-500 Hz supply for use with other transmitters.

SIZE: 22.5" (57 cm) wide, 21.5" (55 cm) deep, and 26.5" (67 cm) high.

WEIGHT: 46 pounds (21 kg).

ACCESS: Access to the tuning controls and meters is available through the hinged front access door. Access to the coarse taps on the loading coil is available through the removable panel above the tuning controls panel.

ELECTRICAL CONNECTIONS: RF input through flexible conduit on the coupler bottom to an internal terminal block connection. Coupler control wire connections to internal terminal block TB1 mounted above the Autotune PWB enclosure. Ground connection to ground lug on exterior. Antenna connection to 1/4" threaded rod in antenna feedthrough bushing.

2 THEORY OF OPERATION, RADIOBEACON

2.1 Functional Description: SS-800AVS

The transmitter signal is generated at low level by amplitude modulating the output of the synthesized carrier oscillator with an audio signal. The audio signal is derived from the summing of a voice type line input signal with a keyed tone code signal.

The audio signal to the modulator is controlled by squelch and automatic-gain-controlled circuitry. Audio line inputs greater than the squelch threshold level are permitted to pass through to the modulator. Amplitude of the line input signals is maintained by the AGC circuit.

The code signal is generated by the Keyer and the Recycle PWB. The 1020 Hz or 400 Hz output of a code tone oscillator is gated on and off by a logic signal from the Keyer. A second gating circuit operated by the squelch detector permits high amplitude code modulation during voice signal absence and low amplitude code modulation during voice signal presence.

The modulated RF signal is filtered and then fed to a linear amplifier consisting of a Class A preamplifier, a push-pull class AB driver stage, and a parallel push-pull class AB final amplifier.

The signal then goes to the antenna system which consists of the antenna coupler and the antenna.

The power supply is a conventional full wave supply capable of delivering 8 amps at 50 volts. The transmitter uses up to 6 amps at full power thus leaving an ample supply for battery charging.

The optional battery system maintains the batteries in a charged state and automatically switches the transmitter to battery power whenever AC power is lost.

Output current is sensed at the final stage to provide an automatic shutdown capability. A current and voltage limiter protects the final circuit from line surges or voltage and current surges in the final.

DC current in one of the final transistors, and RF output power are metered. A DC voltmeter with probe is also built in. A tuning indication is derived from a reflected power measurement in the antenna coupler.

BLOCK DIAGRAM

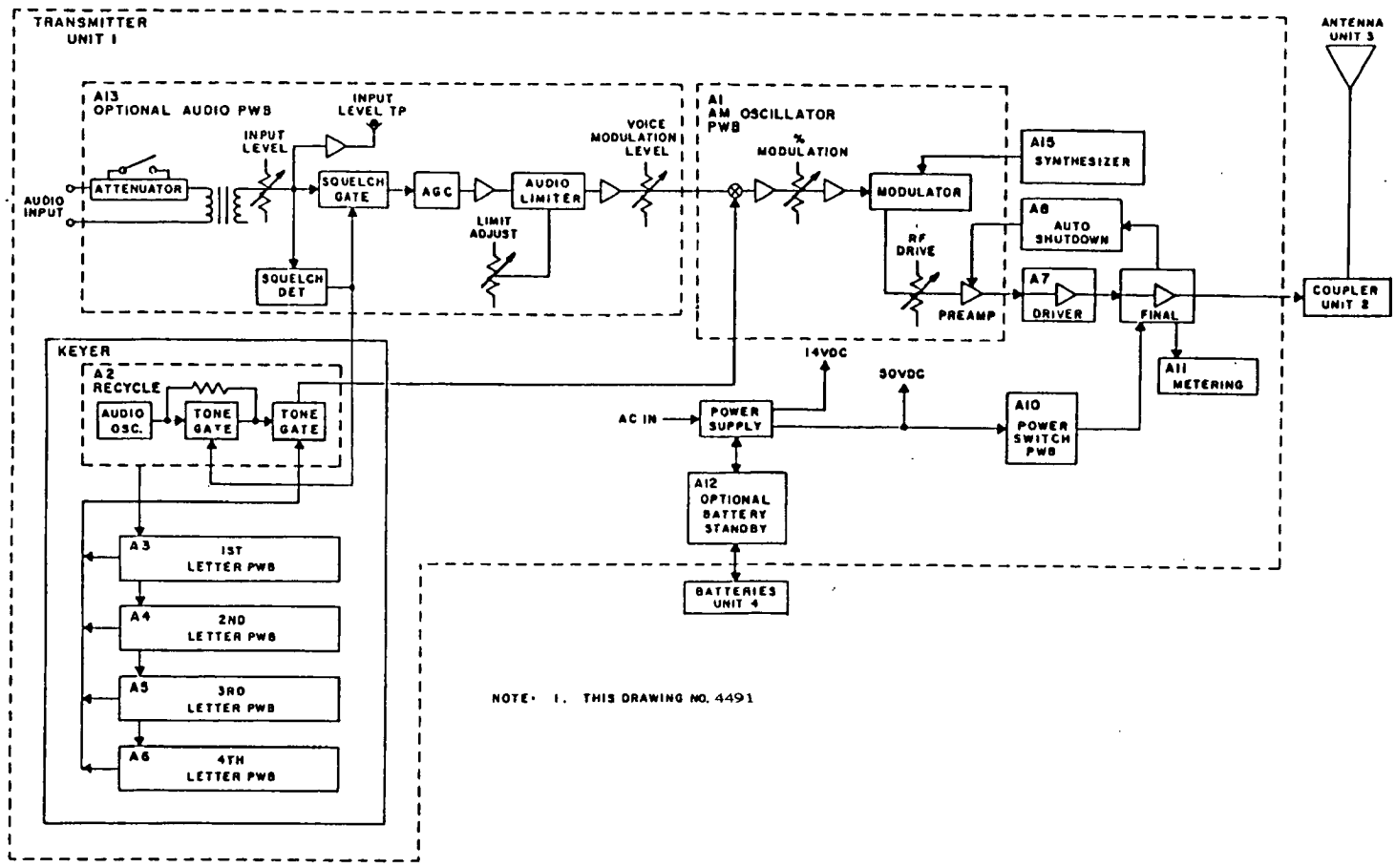

2.2 Detailed Circuit Analysis: SS-800AVS

2.2.1 Synthesizer PWB:

Q1 in conjunction with the components of the Synthesizer Programming PWB and CR1 form a voltage controlled Colpits oscillator. Coarse adjustment of the oscillator frequency is determined by the values of L1, C1, C2, C3, and C4 of PWB 129. L1 is adjusted during initial tuneup to bring the oscillator output to the correct frequency. As the desired frequency is approached, the phase-lock circuits of PWB 128 will capture control of the oscillator tuning by changing the DC bias voltage to capacitance diode CR1. Within the capture tuning region, changes to L1 will produce no change in the oscillator frequency but will cause changes in the CR1 bias voltage. If the oscillator output frequency is less than the switch selected frequency, the bias voltage will be forced to approximately 9 volts, or minimum capacitance in diode CR1. If the oscillator output frequency is higher than the switch selected frequency, the bias voltage will be approximately 0 volts, or maximum capacitance in diode CR1. Monitoring the bias voltage thus enables the technician to rapidly tune the oscillator to the selected frequency. Q2 buffers and amplifies the output of the Q1 oscillator to drive the RF output and the phase-lock logic circuits. The output of buffer Q2 is fed to programmable divider U3 where the oscillator frequency is divided by a number N equal to twice the number selected on the frequency programming switches. For example, if 342 KHz were selected on the programming switches, N would be equal to 684. With the oscillator operating at 342 KHz, an output pulse would occur from U3 at 342 KHz divided by 684 or 500 Hz. The output pulse width from U3 is equal to the length of one cycle at the operating frequency, or 2.9 microseconds at 342 KHz. The 500 Hz U3 output is compared by a phase detector in integrated circuit U2 with a reference 500 Hz signal produced by crystal oscillator and divider U1. The error voltage output from phase detector U2, consisting of a DC voltage with a small 500 Hz ripple, is applied through the low-pass filter (C6, R8, C5, R9, C4) to the capacitance diode CR1. This completes the control loop and enables the locking of the LC oscillator to the crystal reference oscillator. Q3, Q4, and DS1 furnish an indication of a locked state whenever DS1 is lit. This is derived from a lock indication produced in phase-lock detector U2. The synthesizer output signal is fed from pin 2 on the Synthesizer PWB to a modified AM Oscillator PWB.

SYNTHESIZER PWB SCHEMATIC

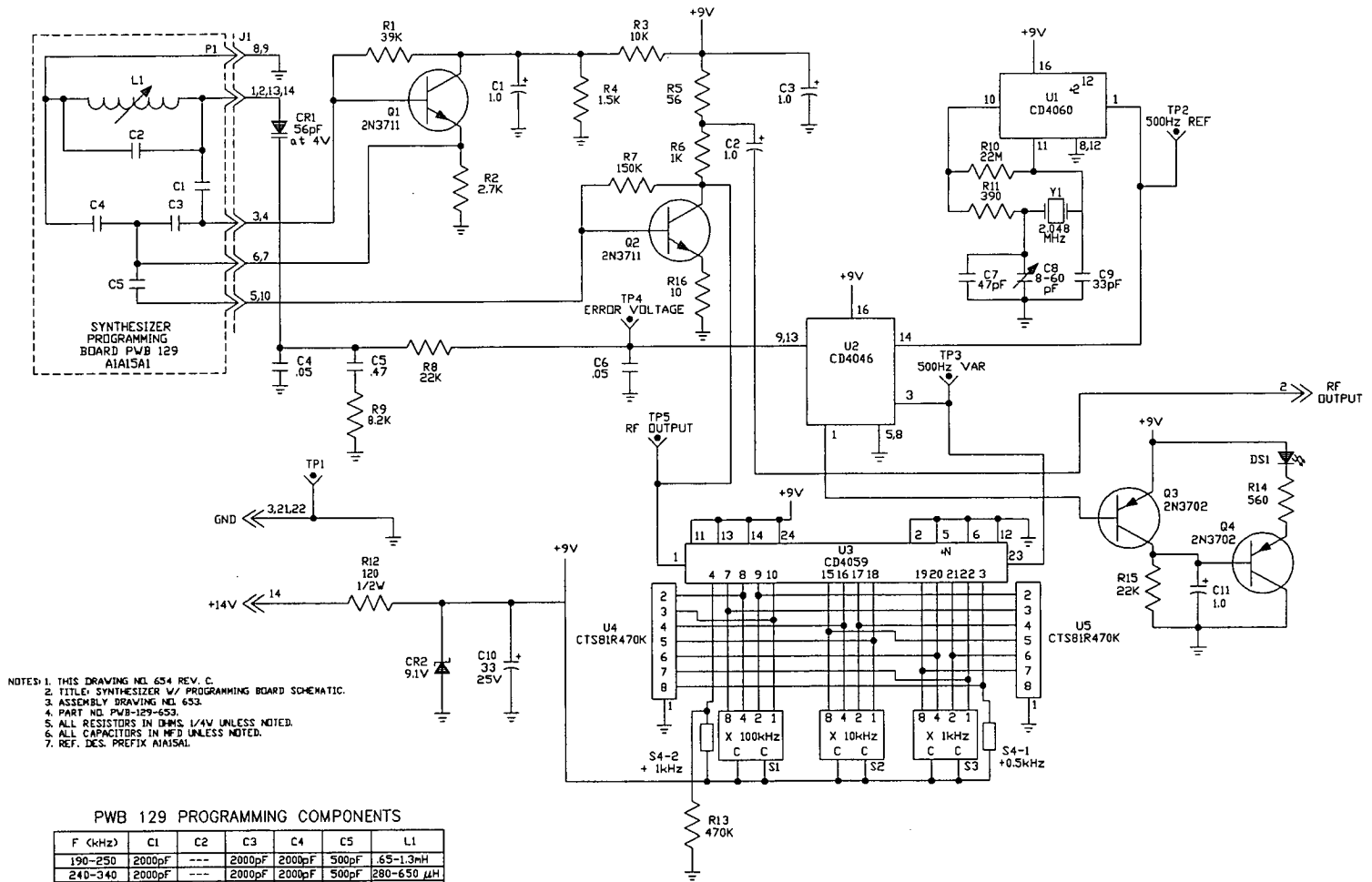

- NOTES: 1. THIS DRAWING NO. 654 REV. C.
 2. TITLE: SYNTHESIZER VFO PROGRAMMING BOARD SCHEMATIC.
 3. ASSEMBLY DRAWING NO. 653.
 4. PART NO. PWB-129-653.
 5. ALL RESISTORS IN OHMS 1/4W UNLESS NOTED.
 6. ALL CAPACITORS IN PFD UNLESS NOTED.
 7. REF. DES. PREFIX AIAISAL.

PWB 129 PROGRAMMING COMPONENTS

F (kHz)	C1	C2	C3	C4	C5	L1
190-250	2000pF	---	2000pF	2000pF	500pF	.65-1.3mH
240-340	2000pF	---	2000pF	2000pF	500pF	280-650 μH
320-415	2000pF	300pF	2000pF	2000pF	250pF	120-280 μH
415-625	2000pF	470pF	2000pF	2000pF	230pF	60-120 μH
500-800	1000pF	300pF	1000pF	1000pF	230pF	60-120 μH
800-1250	1000pF	150pF	1000pF	1000pF	250pF	20-60 μH
15-1.8MHz	1000pF	---	1000pF	500pF	100pF	28-60 μH

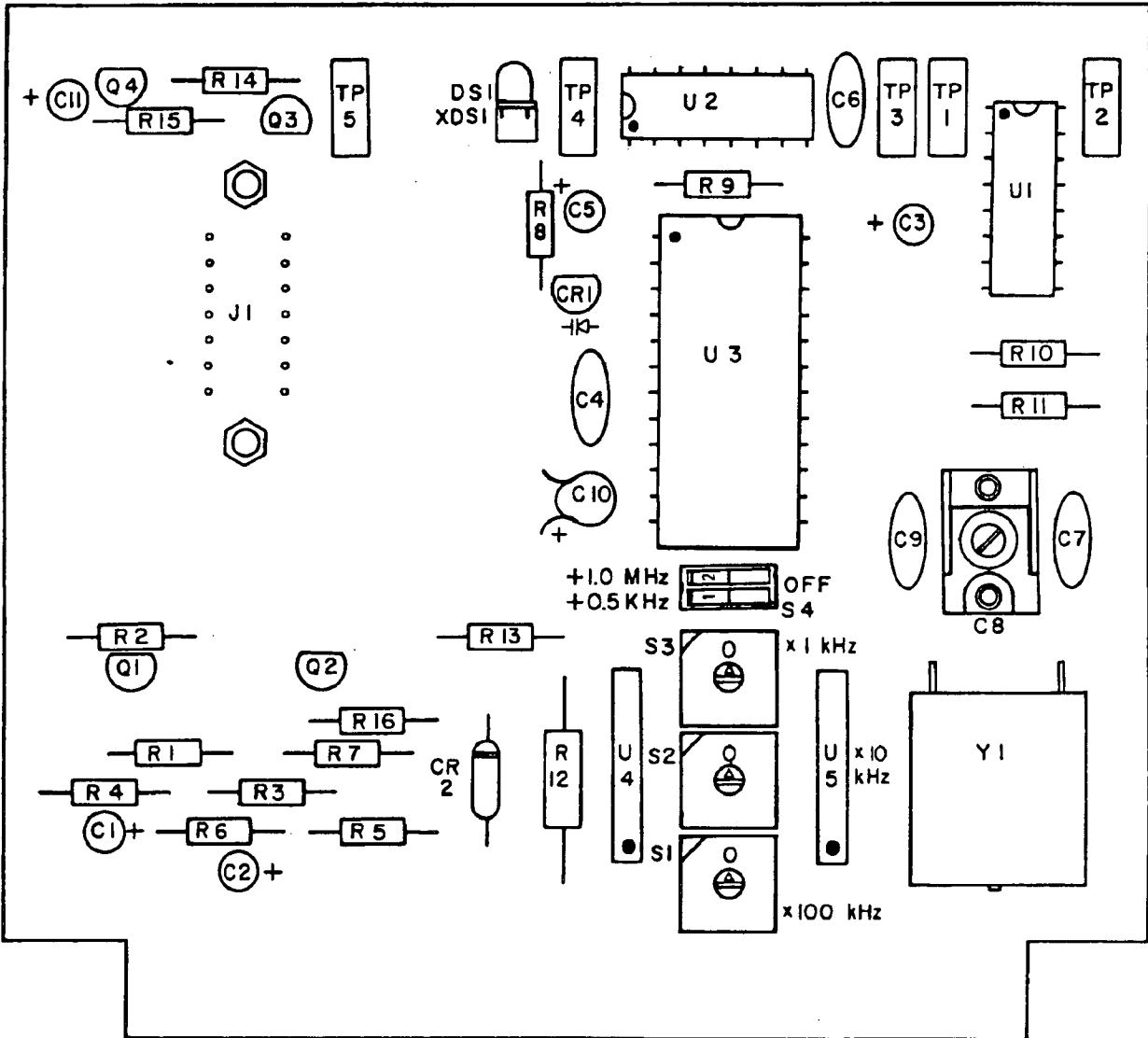

- NOTES: 1. THIS DRAWING NO. 2636 REV. A
 TITLED: SYNTHESIZER PWB ASSEMBLY
2. SCHEMATIC DRAWING NO. 654
3. PART NO. PWB 128-652
4. RES. DES. SSC SERIES A15, SSK SERIES A1A15
5. SEE PARTS LIST.

SYNTHESIZER PWB ASSEMBLY

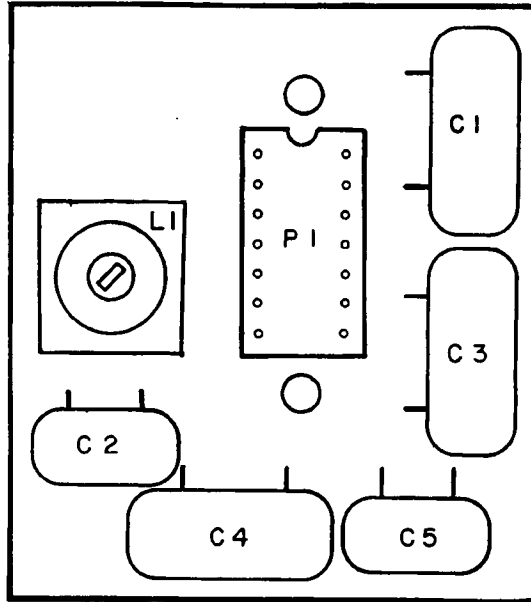

NOTES: 1. REF. DES. PREFIX A1A15A1.
2. PART NO. PWB 129-653.
3. THIS DRAWING NO. 653 REV. B.
4. SEE BOM 653.

SYNTHESIZER PROGRAMMING PWB ASSEMBLY

2.2.2 AM Oscillator PWB

The Synthesizer PWB output is fed to the AM Oscillator PWB at pin 15 and through Q1 and its associated components is applied to the carrier input, pin 8, of the RF modulator integrated circuit U2. After the RF carrier is amplitude modulated in U2, it is filtered by C18, L1, and C19 and applied through RF Drive control R39 and Q3 to the Driver PWB. The switched 14 volts for Q3 is furnished through the Driver PWB from the Auto Shutdown PWB.

The audio input signals to the AM Oscillator PWB are derived from the AM Recycle PWB and/or from the optional Audio PWB. The audio signals are combined in amplifier U1A and applied to Modulation Adjust control R3. The adjusted audio signal is directed through amplifier U1B to the CR1, CR2 symmetrical clipper circuit. Amplifier U1C rolls off the high frequency audio components and applies the signal to the modulator integrated circuit. Test point TP1 allows the audio input to the modulator to be examined.

AM OSCILLATOR PWB SCHEMATIC

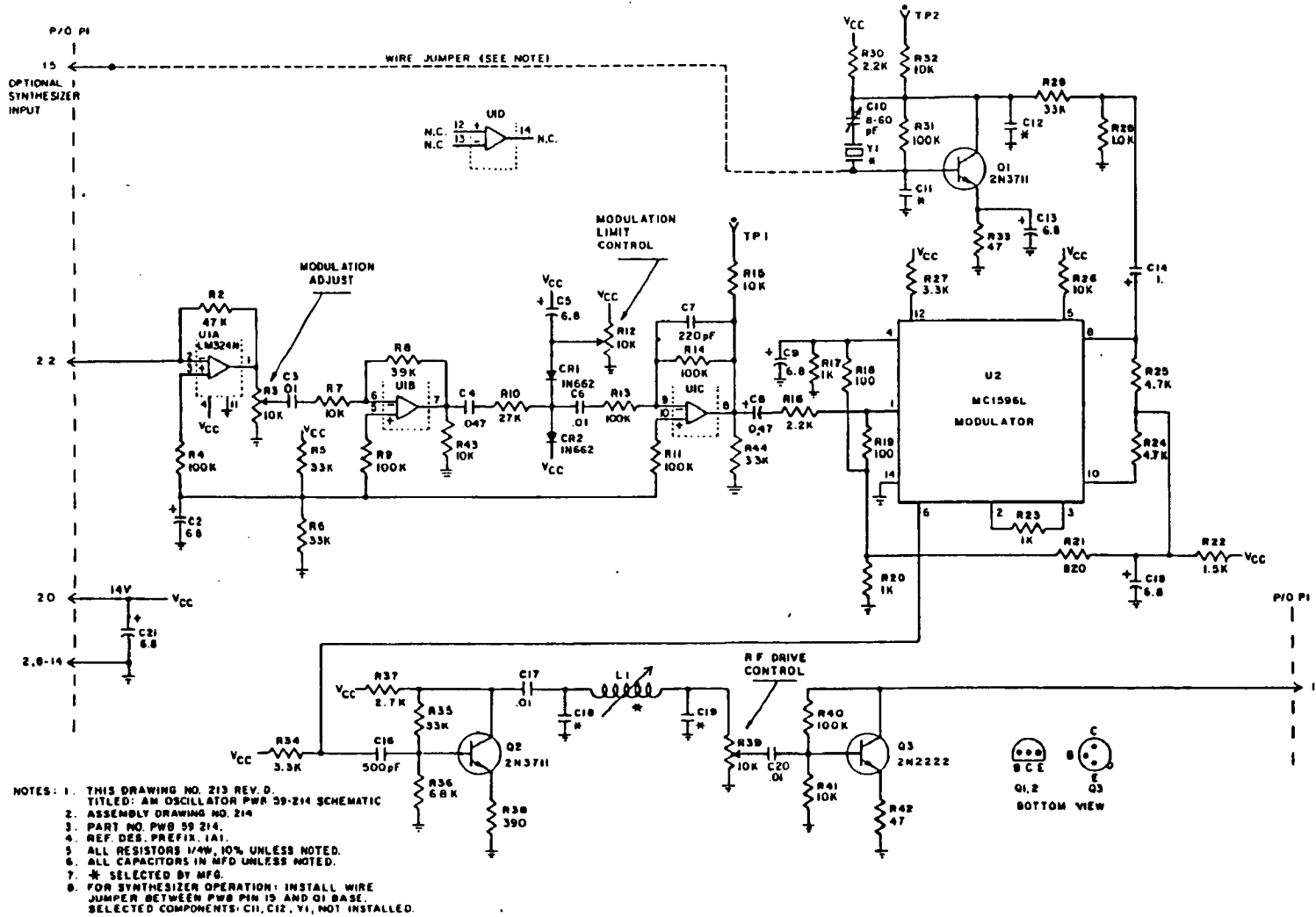

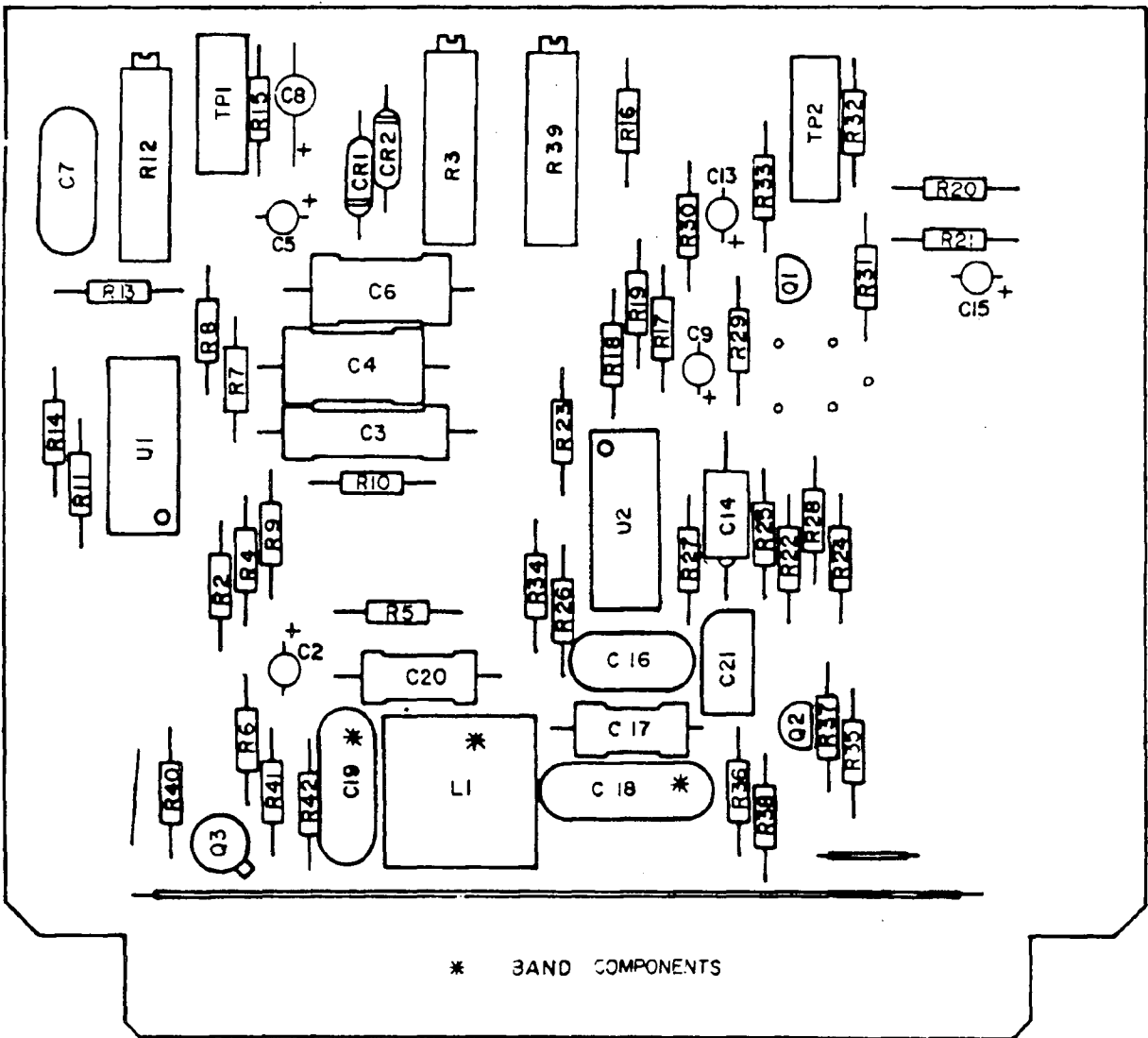

- NOTES: 1. THIS DRAWING NO. 2953 REV.B.
 2. TITLED: AM OSCILLATOR PWB 59-2953
 3. SCHEMATIC DRAWING NO. 213
 4. PART NO. PWB 59-2953.
 5. REF. DES. PREFIX. IAI.
 6. SEE BOM 2953 REV.B.
 7. C1 AND R1 NOT USED.

AM OSCILLATOR PWB ASSEMBLY

2.2.3 Audio PWB (Optional)

The balanced 600 ohm audio input is routed through a switched input attenuator S1, R47, R48, and R49 which allows operation with high level or low level input signals. The signal is then transformer coupled through high pass filter C1, R2, C2, and Audio Input Level control R6 to amplifier U1A and squelch gate U3. The output of U1A drives the audio meter through U1B and the squelch control circuit U1C and U1D. With R6 and input attenuator Switch S1 adjusted for maximum sensitivity, the U1D logic voltage at pin 7 will go to a logic 1, or +12 Volts, as the input signal level rises above -28 dBm. The logic voltage from pin 7 will cause squelch gate U3 to close and apply the audio signal to AGC circuit U2A, Q1, Q2, and Q3. Q1 acts as a variable resistor at the input of U2A. The resistance is controlled by the signal level fed back from pin 1 of U2A. As the signal level increases, the gate voltage on Q1 decreases and the resistance decreases, thus lowering the audio input level to U2A pin 3 and holding the average audio output level constant. Switch S2 enables the AGC action to be inhibited if desired. The audio output of U2A is amplified by U2C and applied to symmetrical clipper CR7, CR8 which prevents overmodulation on sudden audio peaks. R44 adjusts the point at which clipping begins. The clipped signal is amplified and filtered by U2D and U2B, level adjusted by R20, and fed out of the board at pin 9. For special applications, the audio signal can be routed through optional special filter and shaping circuits on an external board attached to Audio PWB pins 7 and 9. The squelch signal at pin 13 is used to control the automatic code tone level reduction during simultaneous voice and code tone modulation.

AUDIO PWB SCHEMATIC

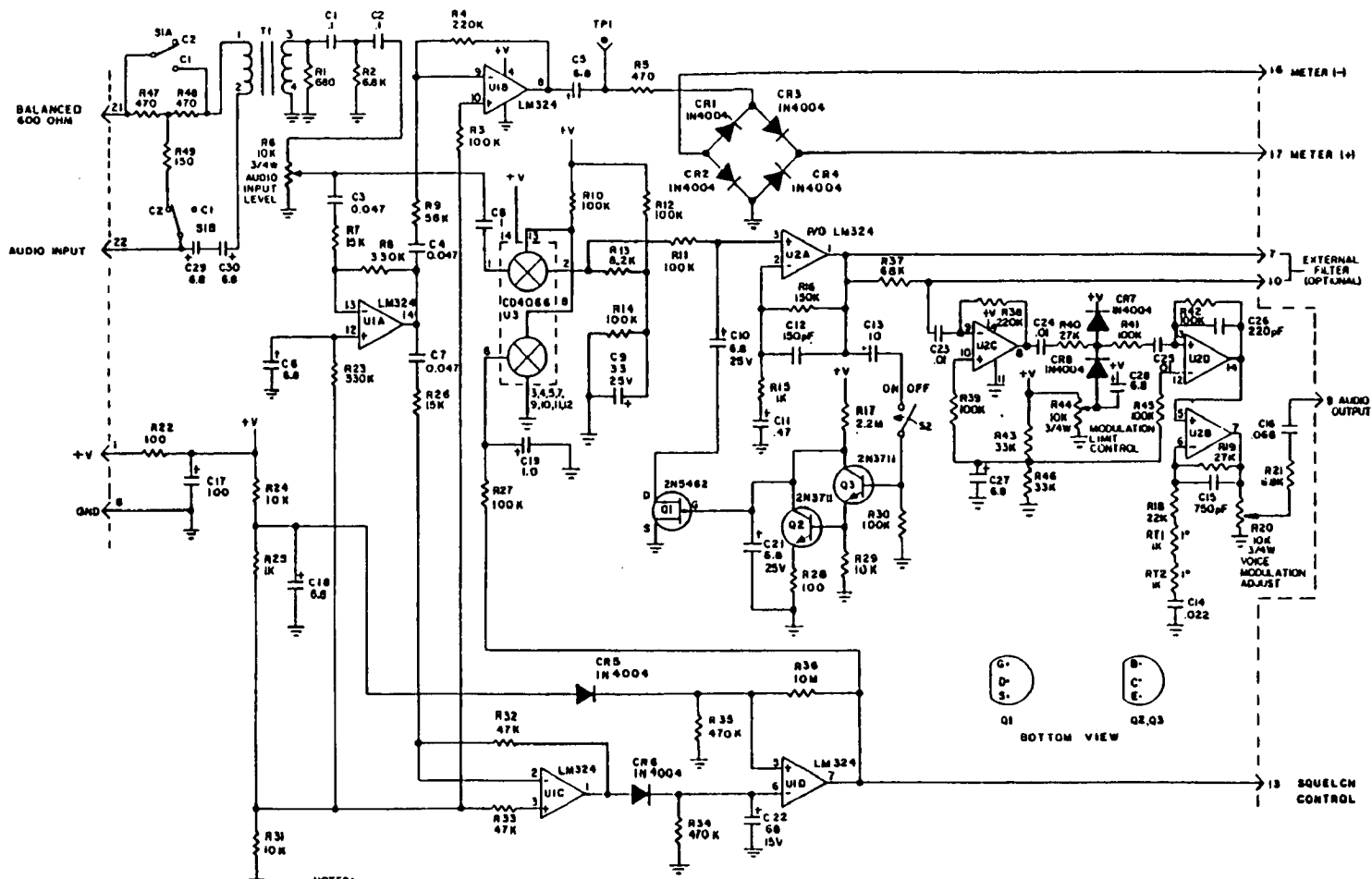

- NOTES:
 1. ALL RESISTORS 1/4W, 10% UNLESS NOTED.
 2. ALL CAPACITORS IN MFD UNLESS NOTED.
 3. REF DES. PREFIX A3A9 38-KLO, A1A13 88K, A13 88C, A1A1A3 SCARAB
 4. ASSEMBLY DRAWING NO. 2063
 5. THIS DRAWING NO. 2062 REV C



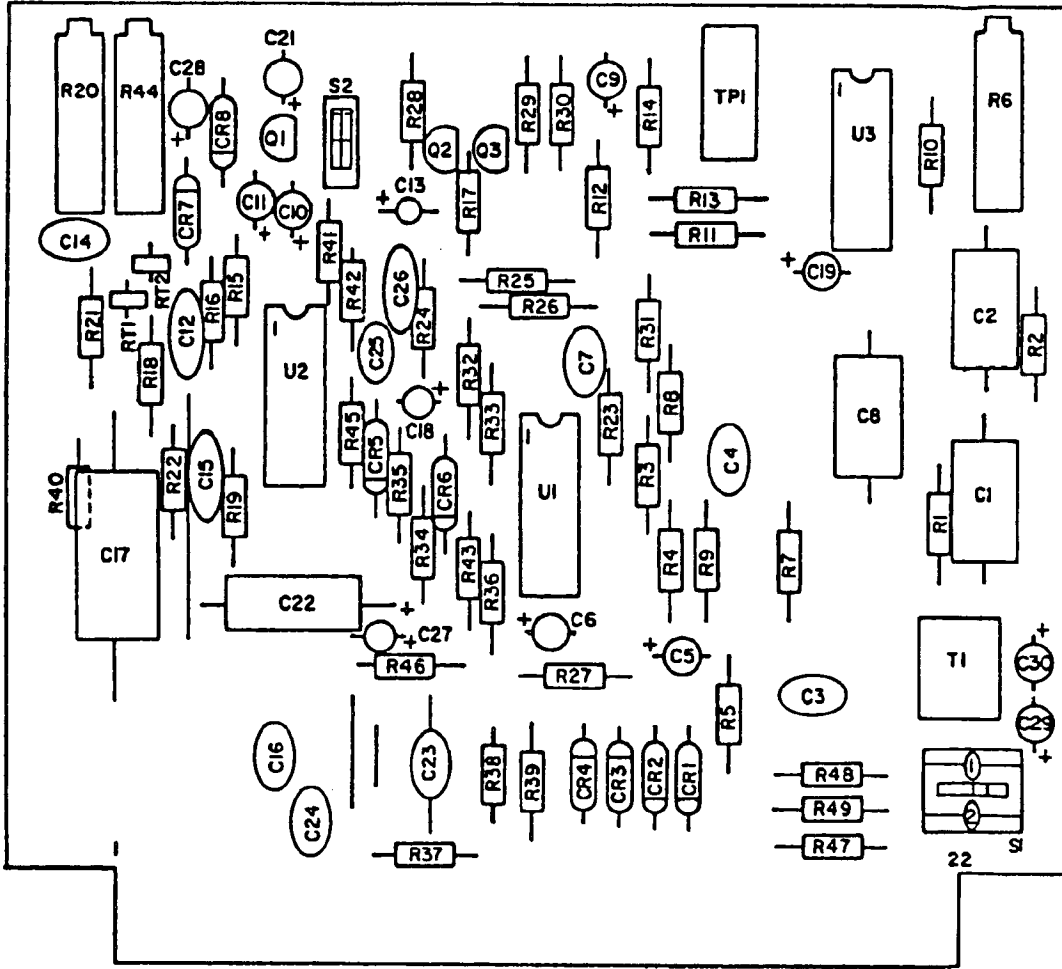

- NOTES: 1. THIS DRAWING NO. 2063 REV. B.
 2. SCHEMATIC DWG. 2062. REV. B.
 3. REF. DES. PREFIX A3A9 SS-KILO, A1A13 SSK, A13 SSC.
 4. PART NO. PWB 214-2063.
 5. SEE BOM 2063 REV. B.
 6. TITLE: AUDIO PWB 214-2063 ASSEMBLY

AUDIO PWB ASSEMBLY

2.2.4 Keyer

The Southern Avionics Keyer is an all solid state International Morse Code generator. The Keyer is designed to generate an identifier of any sequence of up to three letters or numerals automatically at a rate of approximately seven words per minute. The Keyer consists of a Recycle PWB and Letter PWB's plus inter-connecting wiring.

The Recycle PWB generates the gated audio tone, and recycles the ident by initiating the interrogating pulse for the first Letter PWB approximately 3.5 seconds after the last letter has been formed.

Each Letter PWB contains a number of serially connected monostable multivibrators connected in such a manner as to form the dots, dashes, and spaces required to form a letter.

Each PWB provides an interrogating pulse to the following Letter PWB socket, thus cycling the Letter PWB's in a sequence determined by their socket positions. Where a special code is required, such as two or more sequences of letters and then a long pause or a long dash, etc., the keyer can be modified to supply as many letters and/or numerals as required with any timing desired.

2.2.4.1 Letter PWB

These PWB's consist of a series of monostable multivibrators, or one-shots. Each one-shot can generate a dot or dash depending on its R-C time constant.

For example, consider the letter "D" (_..). There are only three characters so the first one-shot is not used. A jumper is placed at J3 to couple the input trigger to the second one-shot. A negative trigger signal is applied to pin 19. This signal comes from the Recycle PWB if "D" is the first letter, or from a letter PWB otherwise. It is a negative pulse supplied through a 10K resistor in series with a 1 μ F capacitor. This switches Q3 off which makes the collector voltage positive. This positive voltage is coupled through CR2 to the logic line which goes to the Recycle PWB and starts the dash for the letter "D". The dash will terminate after the 1 μ F capacitor is charged through R9, and Q3 is switched on, and Q4 is switched off. The pause signal will remain until C3 is charged and Q4 is switched on again. This switches Q5 off. The positive voltage at the collector of Q5 is coupled through CR3 to the logic line and the second character of the letter "D" (a dot) begins. To generate a dot, R15 is in the circuit. This causes the time constant of the charging circuit for C4 to be smaller. When C4 is charged through the parallel combination of R15 and R16, Q4 is switched on again, Q5 is switched off, and the pause signal is generated. When C5 is charged, Q6 is switched on, Q7 is switched off, and the third character of the letter "D" (a dot) is begun.

After C6 is charged through the parallel R22 and R23, Q7 is again turned on and the pause signal begins. This pause signal is longer because of the 1 meg charging path for C7. When C7 becomes charged, Q8 is turned on and the negative signal from the collector of Q8 starts the cycle again at the next Letter PWB. The trigger out connection on the last Letter PWB is open.

Letter PWB's will usually be programmed before shipment from the factory. However, if the Identifier is not known before shipment, unprogrammed PWB's will be supplied. An unprogrammed keyer may be placed in service by performing the following operations on each letter PWB.

- (a) Place a jumper in one of the jumper positions J4 through J1. This jumper marks the start of the letter and would be placed in J4 for a four bit letter, J3 for a three bit letter, etc.
- (b) Observing the Letter PWB schematic and assembly drawing, the letter bits will now be generated in sequence from left to right on the schematic starting with the jumpered stage. Dashes will be generated automatically and any dash may be changed to a dot by adding a 220K ohm resistor in parallel as shown in dotted lines. Also, if J1 is installed remove R21; J2 is installed remove R14; J3 is installed remove R7.

2.2.4.2 Number PWB

Number PWB's are electrically identical to Letter PWB's except for the addition of a fifth multivibrator circuit to generate the fifth bit of a number.

Programming a Number PWB follows the same procedures as programming a Letter PWB. Place a jumper at J5, and place 220K ohm resistors in position where a dot is to be generated. Note that the first bit is position J5, the second bit position J4, etc. Also, if J1 is installed remove R28; J2 is installed remove R21; J3 is installed remove R14; J4 is installed remove R7.

2.2.4.3 AM Recycle PWB

The AM Recycle PWB operates in a normal code identification mode whenever switch S1 on the AM Recycle PWB is in the IDENT position. When S1 is in the CONT position, a continuous tone is generated, and when the switch S1 is in the CARR position, a steady carrier with no modulation is produced.

With switch S1 in the IDENT position and no code being produced, capacitor C1 begins charging through resistors R3, R4, and R5 and reaches approximately 7 volts in 3.5 seconds. When C1 reaches this level, unijunction transistor Q3 fires, creating a trigger pulse through C2, R7, Q4, C3, and R10. The trigger pulse activates the first Letter PWB of the identification sequence (see Letter PWB).

The Logic Output of the Letter PWB's causes Q1 and Q2 to turn ON during keyed code tone output periods. When Q1 and Q2 are ON, the potential on C1 is discharged through CR1, R4, and R5. At the end of the identification sequence, C1 begins to charge as described above, and the identification sequence begins again.

When S1 is in the CONT position, C1 is prevented from charging and initiating the ident sequence. C1 is discharged through CR1, R4, R5, and to ground by S1. The identification code or continuous tone logic signal is taken from the collector of Q2 through R23, to pin 3 of integrated circuit U2 (Quad Transmission Gate).

Integrated circuit U1 (Operational Amplifier) and its associated circuitry function as an audio oscillator to provide an identification tone (1020 Hz or 400 Hz) to pin 1 of U2. The passage of the tone from pin 1 to pins 2 and 3 of U2 is controlled by logic signals produced on the optional Audio PWB. Without an Audio PWB installed, R20 pulls up U2 pin 13, the transmission Gate A control line, and the audio signal passes through Gate A without attenuation. The passage of the tone from pin 3 of U2 through transmission gate B to pin 4 of U2 is controlled by the code signal present at U2 pin 6, with 0 volts at pin 6, and thus 14 V at pins 5 and 9 allowing tone passage through transmission gate B. The audio signal passes through PWB pin 14 or 17 to the audio input, pin 22 of the AM Oscillator PWB. When the Audio PWB senses the presence of a voice input, squelch control input PWB pin 15 will go low to 0 volts. This will cause U2 gate A to stop conducting. The audio tone will bypass gate A through R19 at a reduced amplitude, causing the code amplitude to be about 20% during voice signal presence.

MORSE CODE

Letters

A . -	J . - - -	S
B -	K - . -	T -
C - . - . .	L . - . . .	U . . -
D - . . .	M - -	V . . . -
E .	N - .	W . - -
F . . - .	O - - -	X - . . -
G - - .	P . - - .	Y - . - -
H	Q - - . -	Z - - . .
I . .	R . - .	

Numbers

1 . - - - -	6 -
2 . . - - -	7 - - . . .
3 . . . - -	8 - - - . .
4 -	9 - - - - .
5	0 - - - - -

LETTER PWB SCHEMATIC

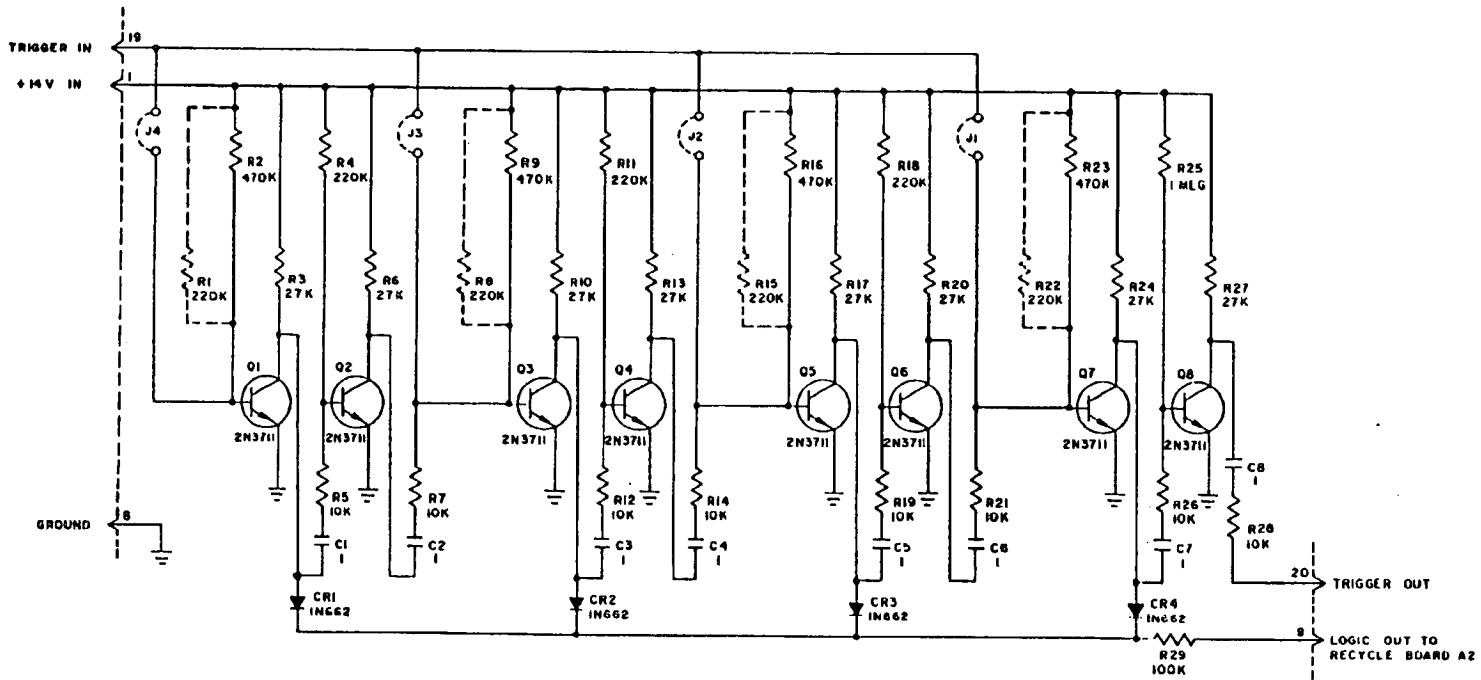

- NOTES. 1. REFERENCE DESIGNATION PREFIX IA3.
 2. ALL RESISTOR VALUES IN OHMS, 1/2 W. 10% UNLESS NOTED.
 3. ALL CAPACITOR VALUES IN MFD UNLESS NOTED.
 4. SEE ASSEMBLY DRAWING NO. 100.
 5. DRAWING NO. 107.
 6. PWB 20.

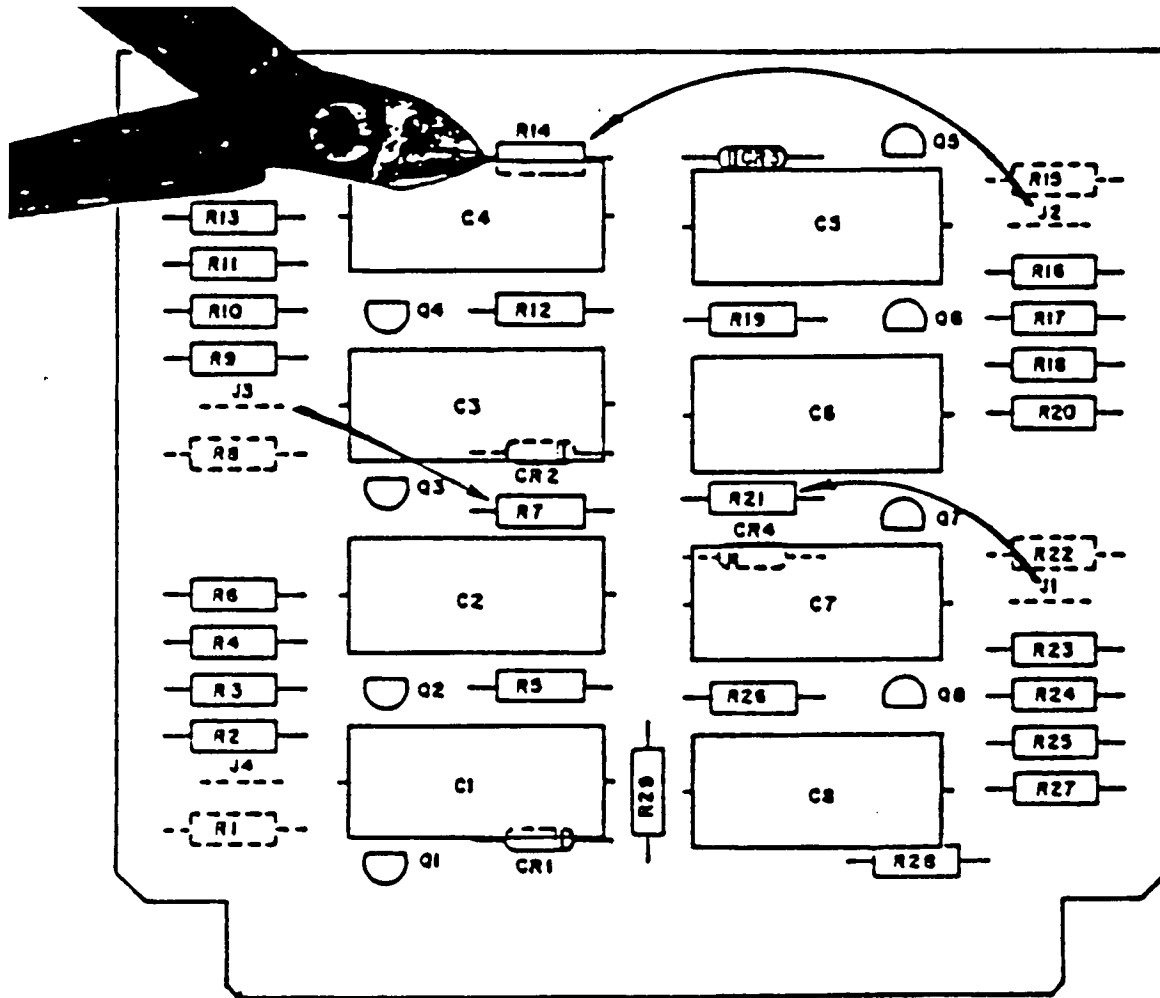

- NOTES.
1. REFERENCE DESIGNATION PREFIX LAJ.
 2. SEE SCHEMATIC DRAWING NO. 187. REV. A.
 3. PART NO. PWB 28-189. REV. D.
 4. THIS DRAWING 3908 REV. A.
 5. SEE BOM 189

LETTER PWB ASSEMBLY

NUMBER PWB SCHEMATIC

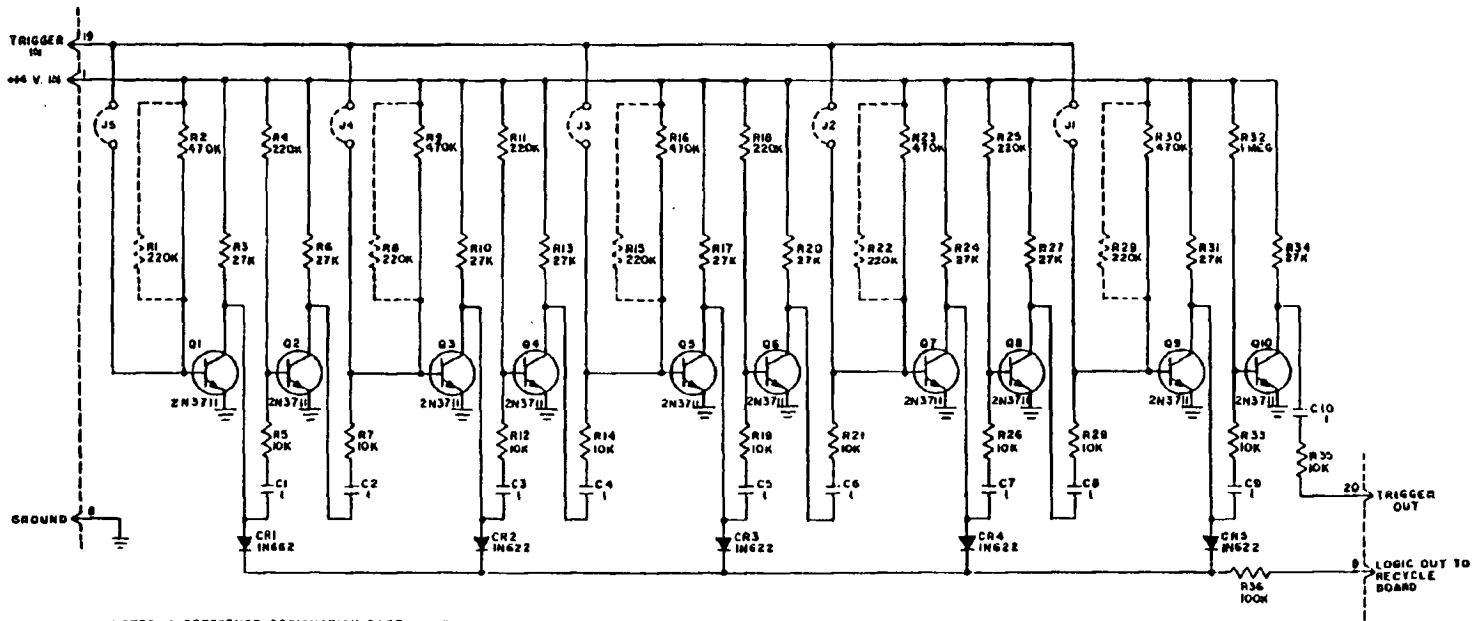

- NOTES: 1. REFERENCE DESIGNATION PREFIX 1A3
 2. ALL RESISTOR VALUES IN OHMS, 10%, 1/4W
 3. ALL CAPACITOR VALUES IN MFD
 4. SEE ASSEMBLY DRAWING NO. 297
 5. THIS DRAWING NO. 296
 6. PWB 40.

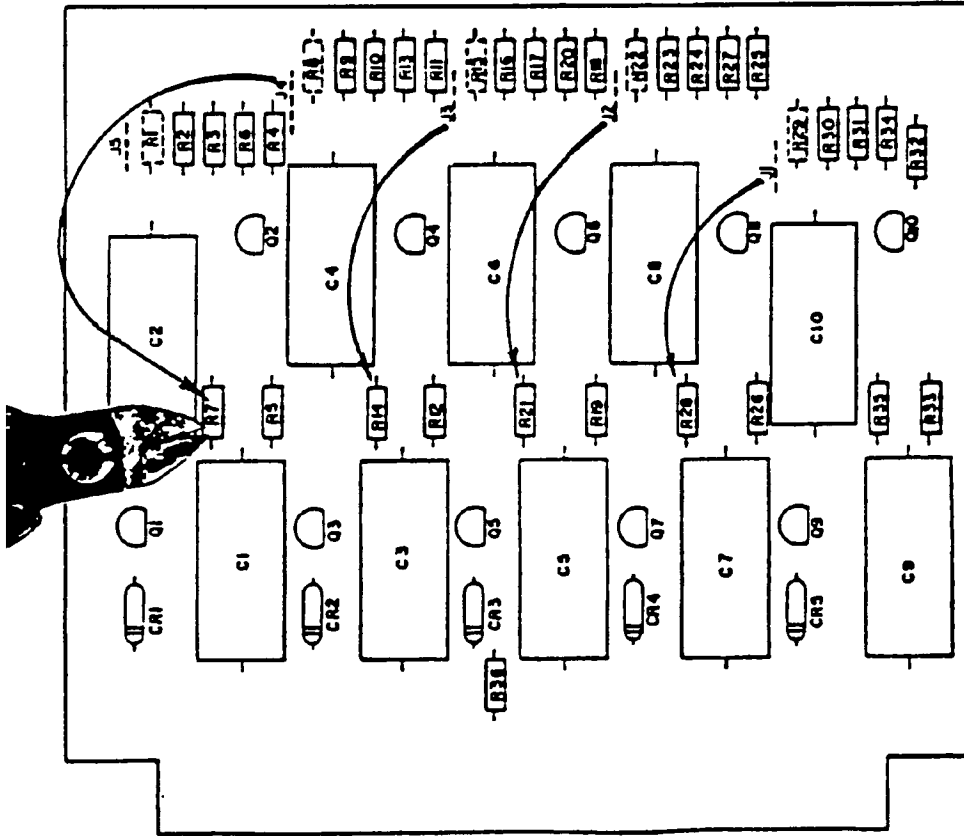

- NOTES.
1. REFERENCE DESIGNATION PREFIX 1A3.
 2. SEE SCHEMATIC DRAWING NO. 296. REV. A.
 3. THIS DRAWING 3909 REV. A.
 4. PART NO. PWB 40-297. REV. B.
 5. SEE BOM 297 REV. A.

NUMBER PWB ASSEMBLY

AM RECYCLE PWB SCHEMATIC

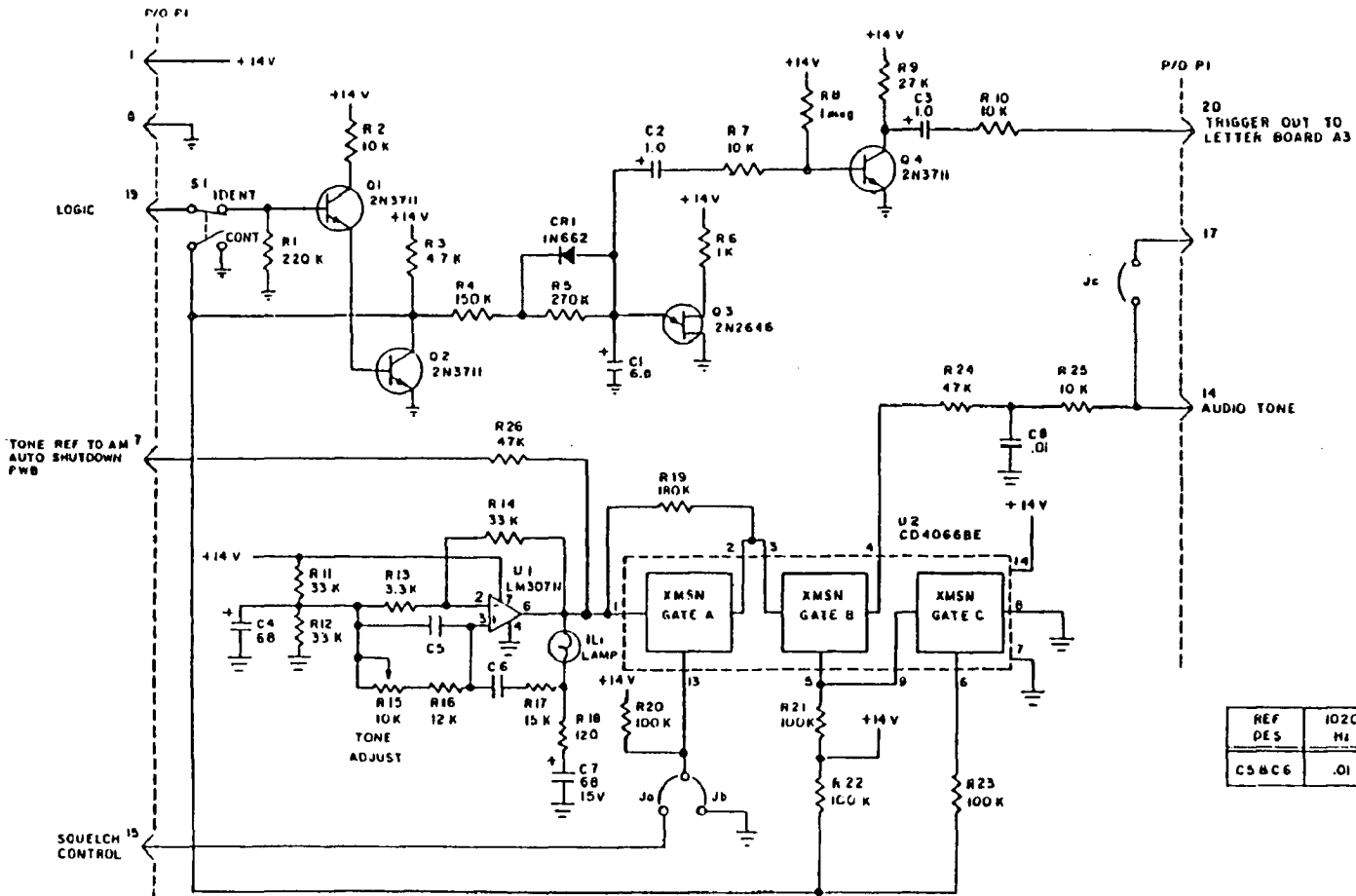

REF	1020	400
DES	Hz	Hz
C5 & C6	.01	.022

- NOTES: 1 ALL RESISTORS 1/4 W, 10% UNLESS NOTED.
 2. ALL CAPACITORS IN MFD UNLESS NOTED
 3 ASSEMBLY DRAWING FOR 400Hz MIXERS, FOR 1020Hz NO 3002.
 4. THIS DRAWING NO 510 REV B.
 5 REF DES PREFIX 1A2
 6 PWB 60.

2.2.5 Driver PWB

Q1 and Q2 form a class AB push-pull driver for the final. The input signal from Q3 on the Oscillator PWB is transformer coupled through T1 to this stage and the output signal is coupled to the final stage through T2.

Test point 4 (TP4, blue) is used to monitor the signal from the preamp and the DC voltage on the preamp. This voltage is controlled by the automatic shutdown circuit. Test point 2 (TP2, red) is used to monitor the driver output as well as the DC supply voltage (50V). Test point 3 (TP3, yellow) is used to monitor the input signal to the final as well as the bias voltage on the final amplifier. The black test point (TP1) is ground.

DRIVER PWB SCHEMATIC

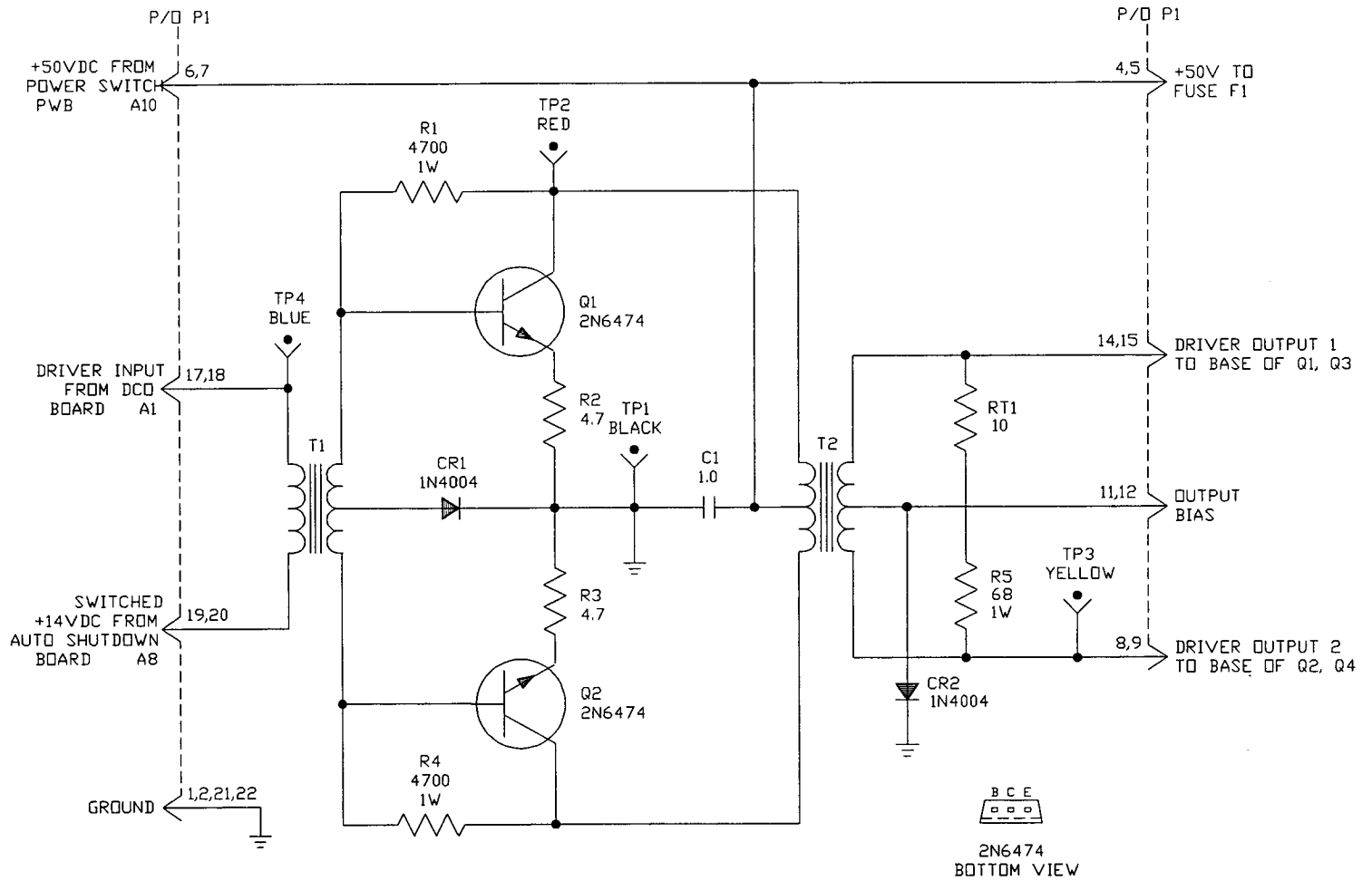

- NOTES: 1. THIS DRAWING NO. 4121. REV. B.
 2. TITLE: DRIVER PWB SCHEMATIC.
 3. ASSEMBLY DRAWING NO. 4109.
 4. REF DES PREFIX 1A7.
 5. ALL RESISTORS 1/2W, 10% UNLESS NOTED.
 6. ALL CAPACITORS IN MFD UNLESS NOTED.

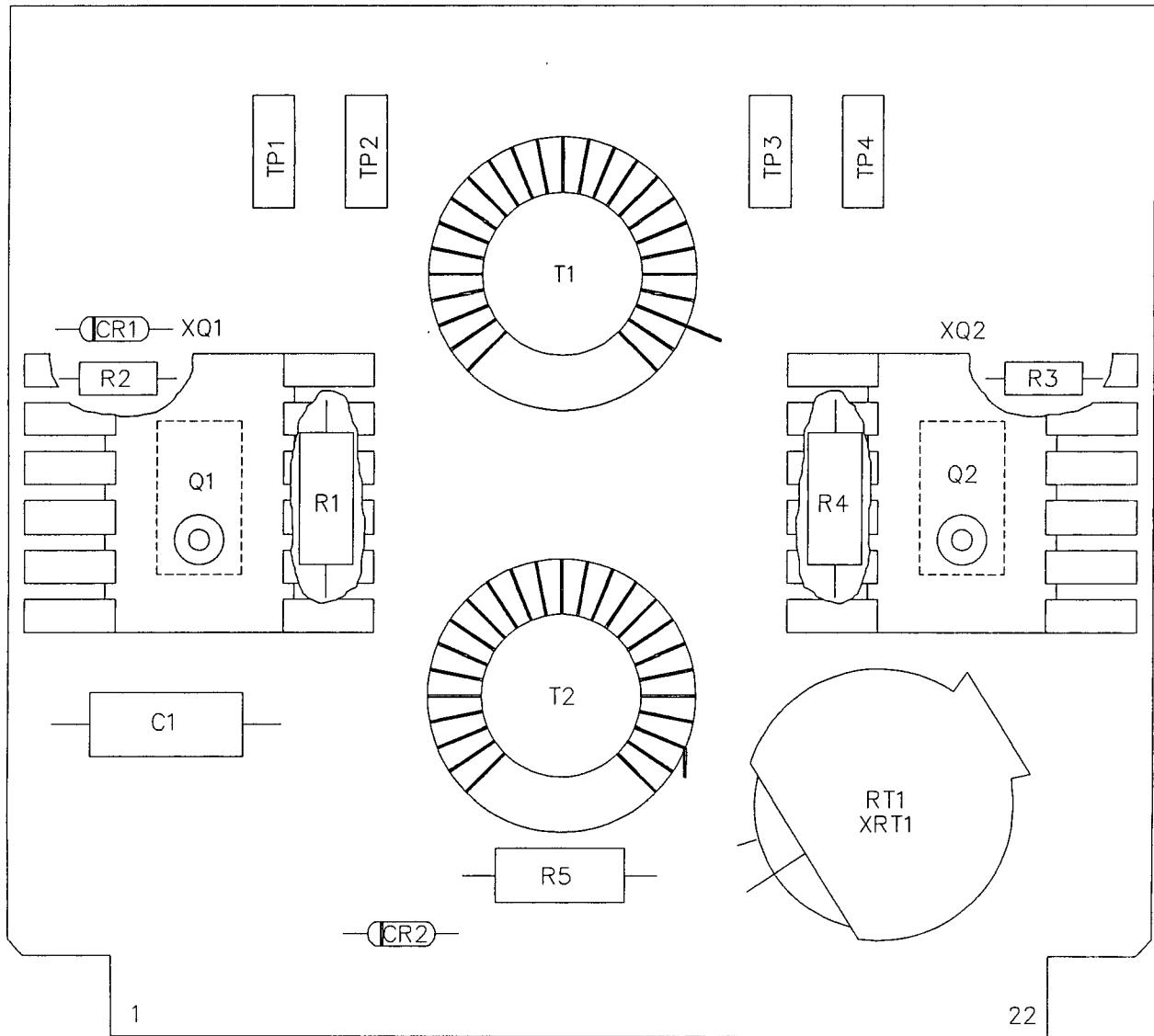

- NOTE: 1. THIS DRAWING NO. 4109 REV. A.
 2. TITLE: DRIVER PWB ASSEMBLY
 3. SCHEMATIC DRAWING NO. 4121
 4. PART NO. PWB 222-4109
 5. REF. DES. PREFIX 1A7

DRIVER PWB ASSEMBLY

2.2.6 Final Stage

The final stage is a parallel push-pull class AB amplifier formed by Q1, Q2, Q3, and Q4. These transistors are matched at the factory with a specific range of current gain. CR4, CR5, CR7, CR8, R5, R9, R15 and R19 provide protection when an inductive load or open circuit causes large voltage spikes at the transistor collectors. T2 impedance matches the circuit to a 50 ohm output. The pi network C5, L1, and C6 is a lowpass filter.

FINAL STAGE SCHEMATIC

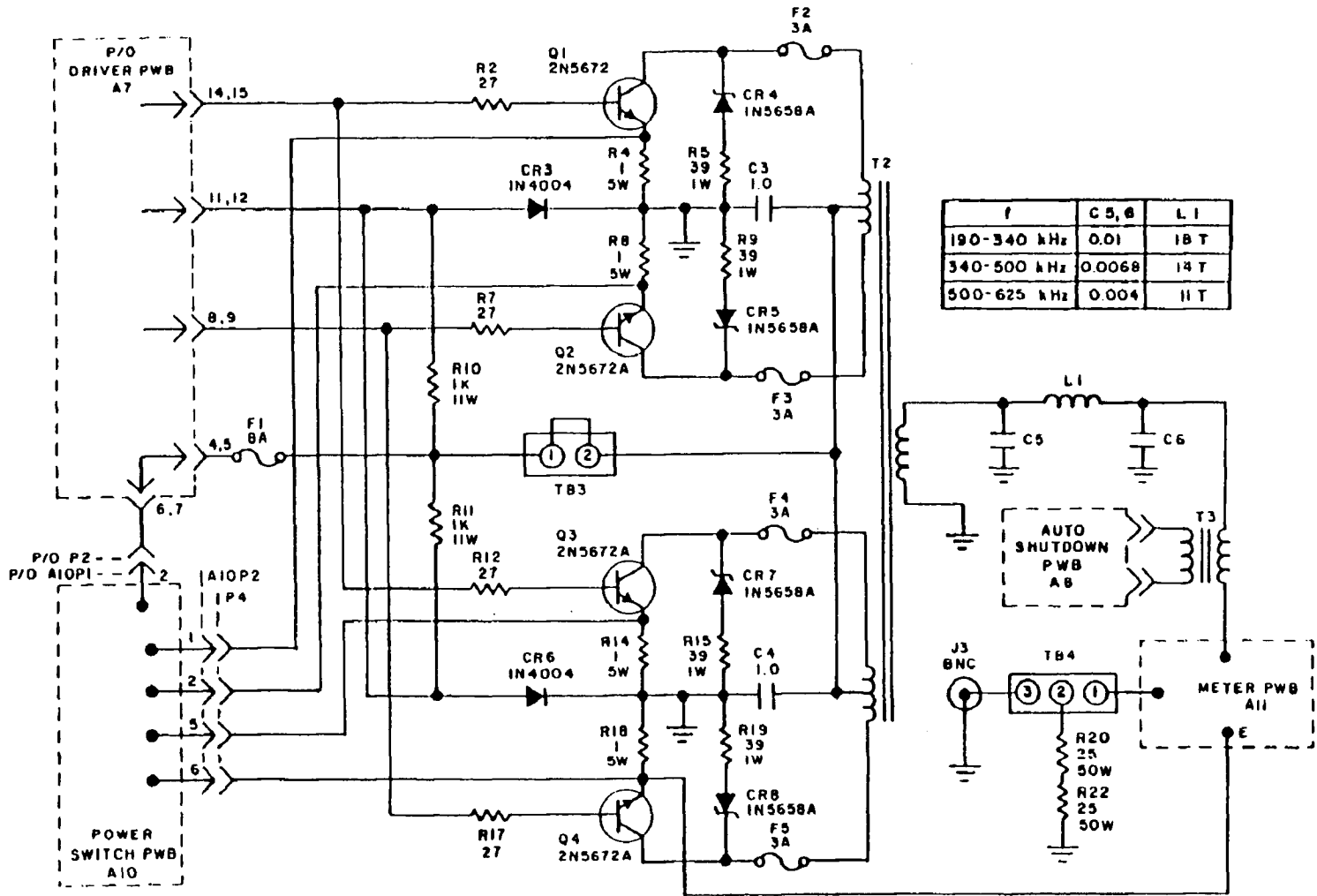

- NOTES: 1. THIS DRAWING NO. 660 REV. H.
 TITLED: SS-800A FINAL STAGE SCHEMATIC
 2. REF. DES. PREFIX I.
 3. ALL RESISTORS 1/2W, 10% UNLESS NOTED.
 4. ALL CAPACITORS IN MFD UNLESS NOTED.

2.2.7 Power Supply

The main supply is a full wave rectified capacitor filtered 50 VDC supply. At normal loading of about 6 amps, the peak to peak ripple will be approximately one volt.

The 14 volt regulated supply for the Keyer, AM Oscillator PWB, Audio PWB, and Auto Shutdown PWB is mounted on the Auto Shutdown PWB.

50 V POWER SUPPLY SCHEMATIC

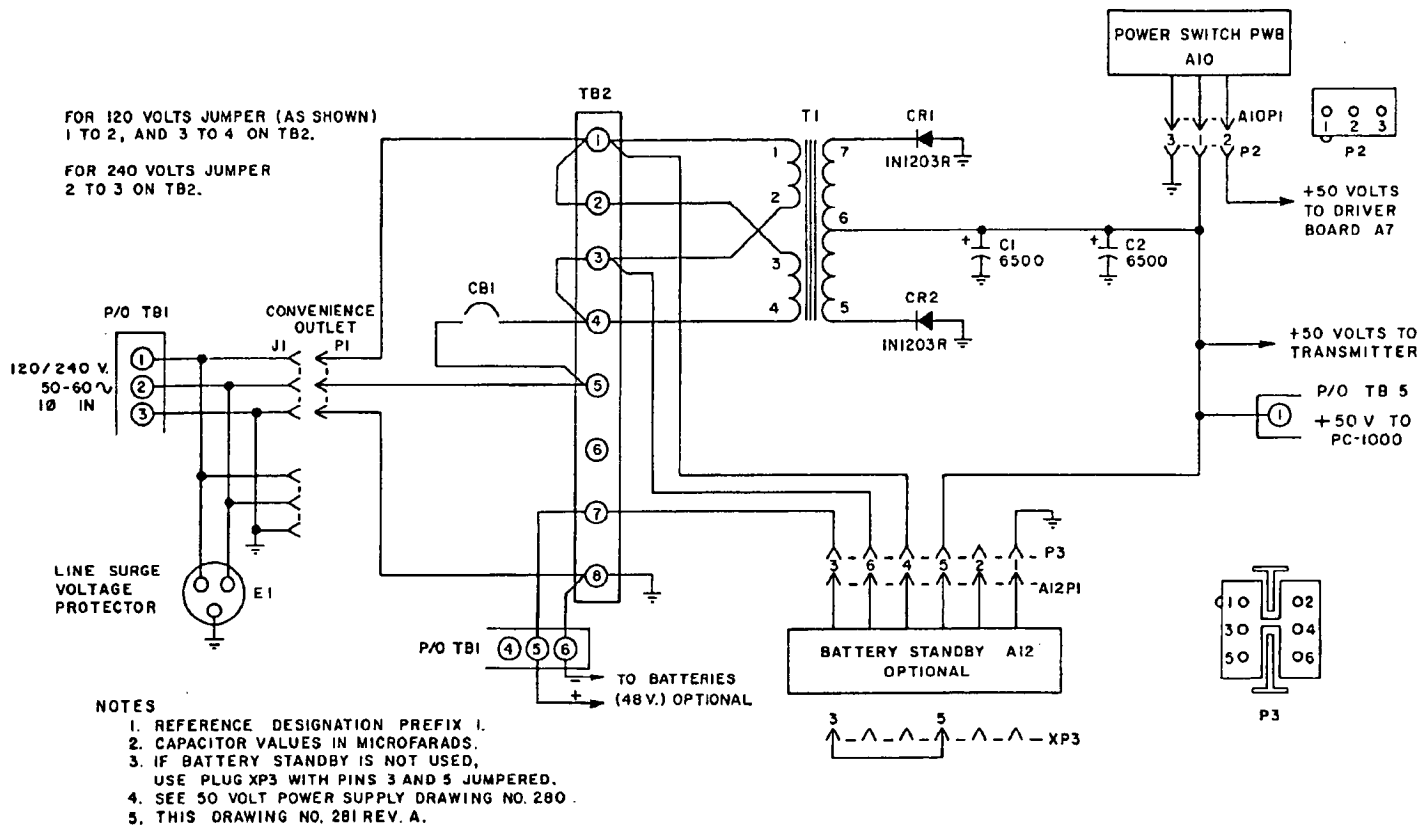

SS-800AVS

Southern Avionics
Company

43

50 VOLT POWER SUPPLY

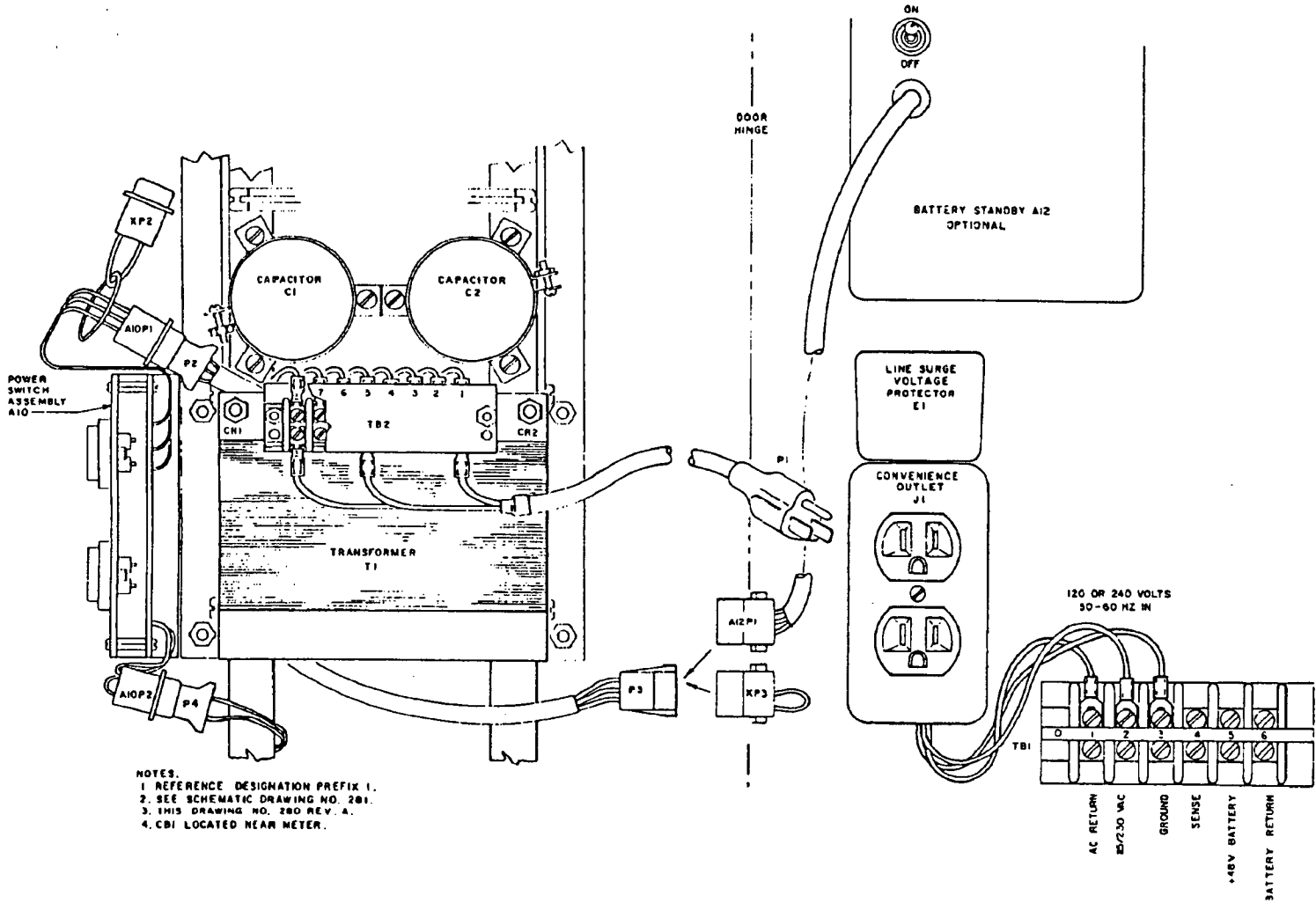

- NOTES.
1. REFERENCE DESIGNATION PREFIX 1.
2. SEE SCHEMATIC DRAWING NO. 281.
3. THIS DRAWING NO. 280 REV. A.
4. CBI LOCATED NEAR METER.

2.2.8 Battery System

The optional Battery Standby System automatically switches the transmitter to battery power in case of AC power failure, and automatically keeps the batteries charged under normal conditions.

The battery charger operates in two modes of operation during charging, depending upon the state of charge of the batteries. The charger initially operates in a constant current charging mode until the battery voltage rises to an equalizing voltage of approximately 55 volts. The charger then switches to a voltage regulating mode to maintain the battery voltage at a float voltage of approximately 52.4 volts (adjustable). A light emitting diode on the battery charger PWB indicates whether the current regulating mode (LED OFF) or voltage regulating mode (LED ON) is active. When the voltage regulating mode is active, the battery float voltage can be adjusted with R22.

During charging, power to the batteries is furnished from the transmitter +50 volt supply with the voltage boosted 10 to 15 volts by T1 and CR1-CR4. Charging current is regulated at approximately 2 amps maximum with current sensed across R7 and R8, and current level controlled with Q1, Q2 and Q3. U1, R17 and CR10 latch the charger into a current regulating mode. After the battery voltage reaches an equalize voltage of about 55 volts, CR10 reverse biases and switches the charger to a voltage regulating mode with float level voltage regulation through U1, Q6, Q2 and Q8. Float voltage level is set for 52.4 volts for 24 cell lead acid batteries. For Nickel Cadmium batteries, the normal float voltage is approximately 1.40 volts per cell or 53.2 volts for a 38 cell battery.

During discharge, current flows through CR12, RT1, RT2 and K1 to the transmitter. Battery voltage is monitored through CR12. If the battery voltage drops below approximately 38 volts, flip-flop U3 is set, turning off Q4 and opening K1. Power is thus removed from the transmitter. Flip-flop U3 is reset with power again being applied to the transmitter when AC power is momentarily reapplied or power is removed from the battery charger by turning off S1. When AC power is present, Q4 and K1 are maintained in the OFF state.

SSC BATTERY STANDBY SCHEMATIC

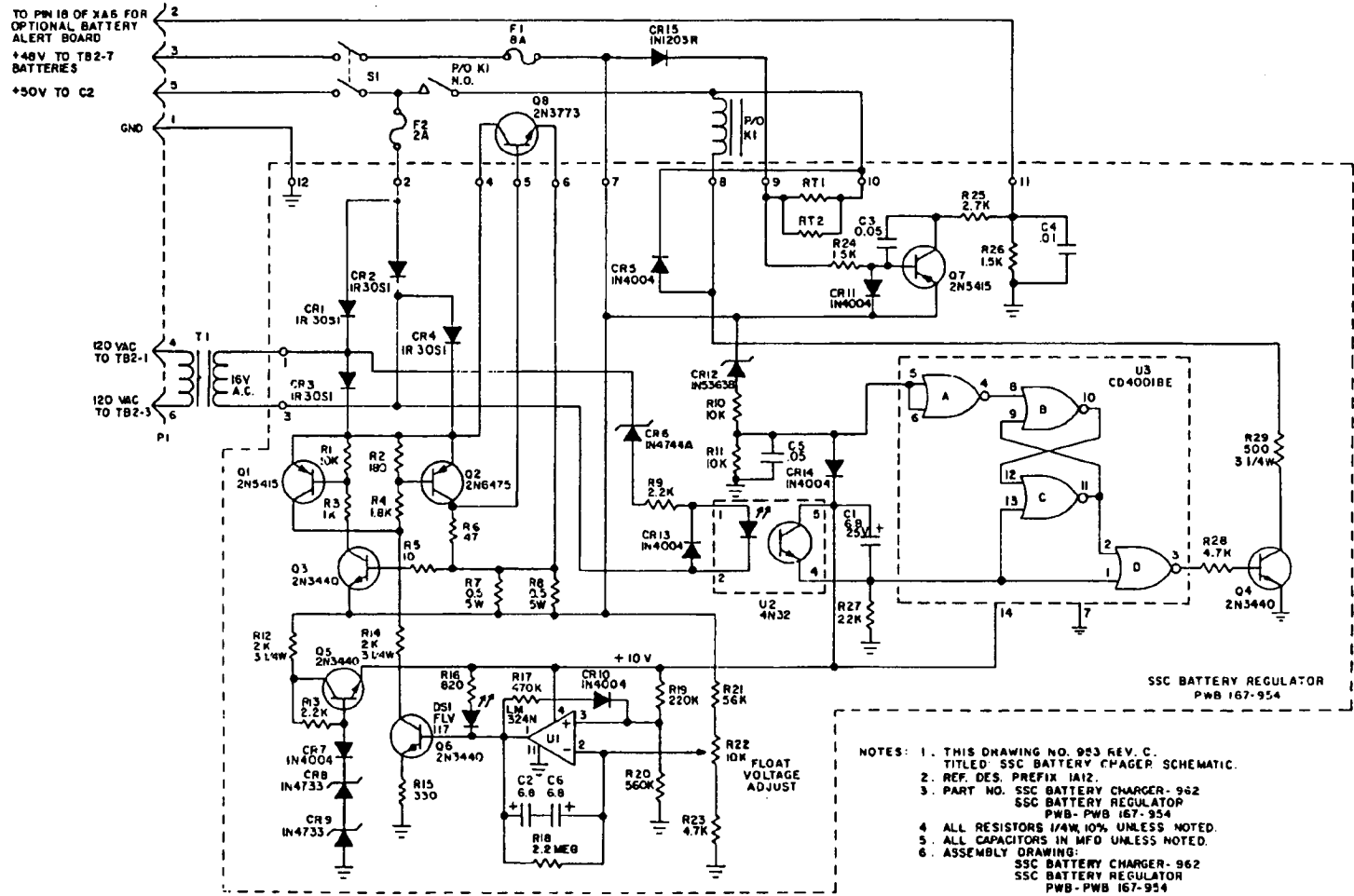

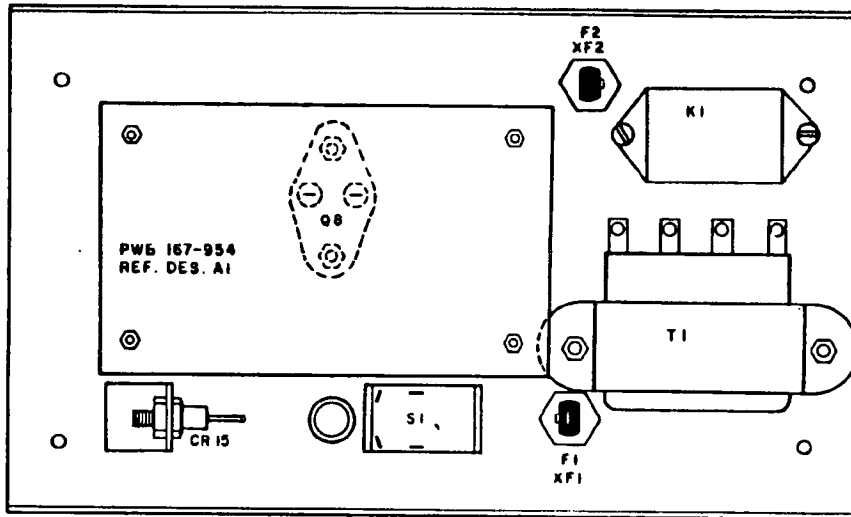

- NOTES 1. THIS DRAWING NO. 2658 REV. B.
 TITLED: SSC BATTERY CHARGER
 2. SCHEMATIC DRAWING NO. 953
 3. REF. DES. PREFIX. A12
 4. SEE PARTS LIST 2658 P/O BOM 962

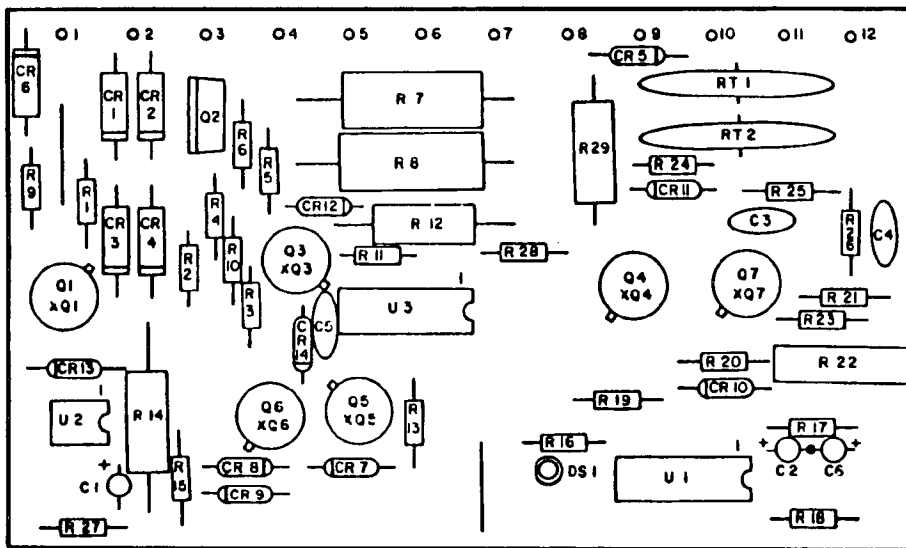

- NOTES: 1. THIS DRAWING NO. 954 REV. D.
 TITLED: SSC BATTERY REGULATOR PWB 167-954
 2. SCHEMATIC DRAWING NO. 953
 3. REF. DES. PREFIX IA12.
 4. PART NO. PWB 167-954.
 5. SEE BOM 954
 6. SEE WIRE LIST WL-954.
 7. R7,8,12,14,29 SHOULD BE MOUNTED STANDING
 OFF OF BOARD.

SSC BATTERY STANDBY ASSEMBLY

2.2.9 AM Auto Shutdown PWB

The Auto Shutdown PWB incorporates detectors and logic circuits to monitor output current and modulation.

The output RF current level is coupled by a sense coil to the PWB input where it is detected by diode CR6. The demodulated signal has both a DC component proportional to RF current level, and an AC component proportional to the modulation level. The level of these components is adjusted by R6. The two components are then separated with the DC component going to U1 pin 3 and U2 pin 1. The DC signal applied to U1 pin 3 is compared with a reference level established by R8 and R9. When the transmitter RF output current drops below the reference at U1 pin 2, a low power level condition will be signaled as U1 pin 1 goes to approximately 0.5 VDC. This will force TP2 low, resulting in eventual transmitter shutdown.

The AC component of the detected signal, which may contain both voice and tone identification signals, is fed through R6 to synchronous detector U2 where the tone is separated out and detected. U2, a transmission gate, turns on and off between pins 1 and 2 synchronously with a reference tone obtained through U1 B from the AM Recycle PWB. The output, U2 pin 2, of the synchronous detector is a DC voltage proportional to the modulating level of the identifying tone. The DC level from U2 pin 2 is compared at U1C pin 10 with a carrier reference level at U1C pin 9. The presence of a tone modulation percentage higher than that established by R22 is indicated by a +14 V signal on U1C pin 8. A low-tone level will be indicated by a .5 V signal at U1 pin 8. With the transmitter operating properly, U1 pin 1 will be approximately +14 V and U1 pin 8 will alternate with the code tone pulses between approximately +14 V and 0.5 V. TP2 (Yellow) will alternate between +14 V and +6 V. The transitions in the TP2 voltages are coupled through C5 to Q2. This turns on Q2 and prevents C6 from charging through R12 and R13. If the RF current or tone modulation percentage drops below the levels set by R6 and R22 respectively, TP2 will be held at +1.5 V or 6 V respectively, causing C6 to charge through resistors R12 and R13 firing unijunction transistor Q7 after a nominal 25 second delay. If the tone is on continuously, C5 will charge, and Q6 will not turn on, with the same end result. Q7 fires the SCR which then applies a 0 volt signal to the base of Q4, turning Q4 and relay K1 off, and removing the 14 V supply from the preamplifier. This completely turns off the RF output until the SCR is again reset by opening switch S1.

Also included on the Auto Shutdown PWB is a 14 volt regulated power supply.

AM AUTO SHUTDOWN PWB SCHEMATIC

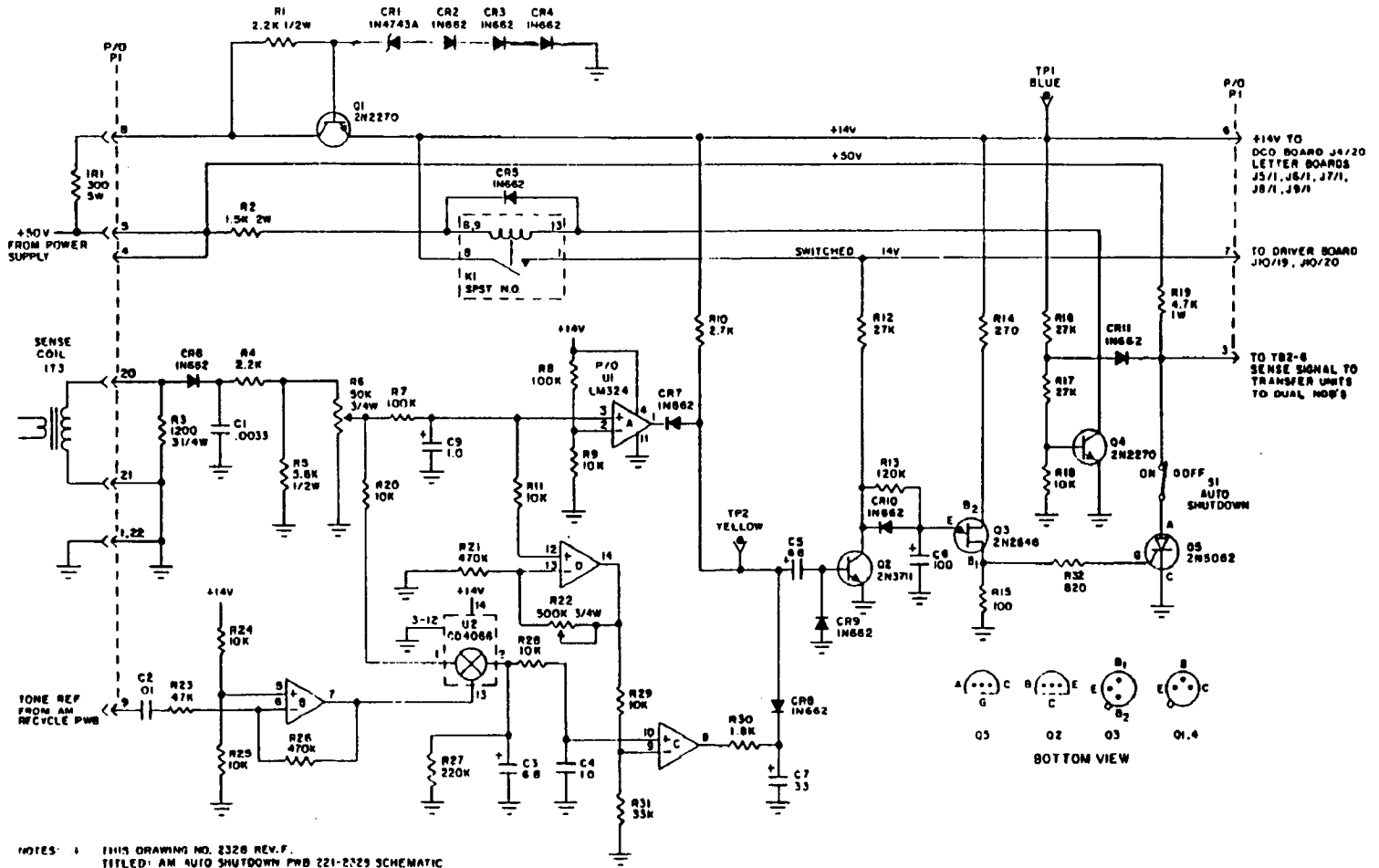

- NOTES: 1. THIS DRAWING NO. 2328 REV.F.
 TITLED: AM AUTO SHUTDOWN PWB 221-2329 SCHEMATIC
 2. ASSEMBLY DRAWING NO. 2329.
 3. REF DES PREFIX
 4. ALL RESISTORS 1/4W, 10% UNLESS NOTED
 5. ALL CAPACITORS IN MFD UNLESS NOTED.

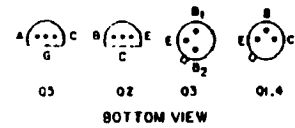

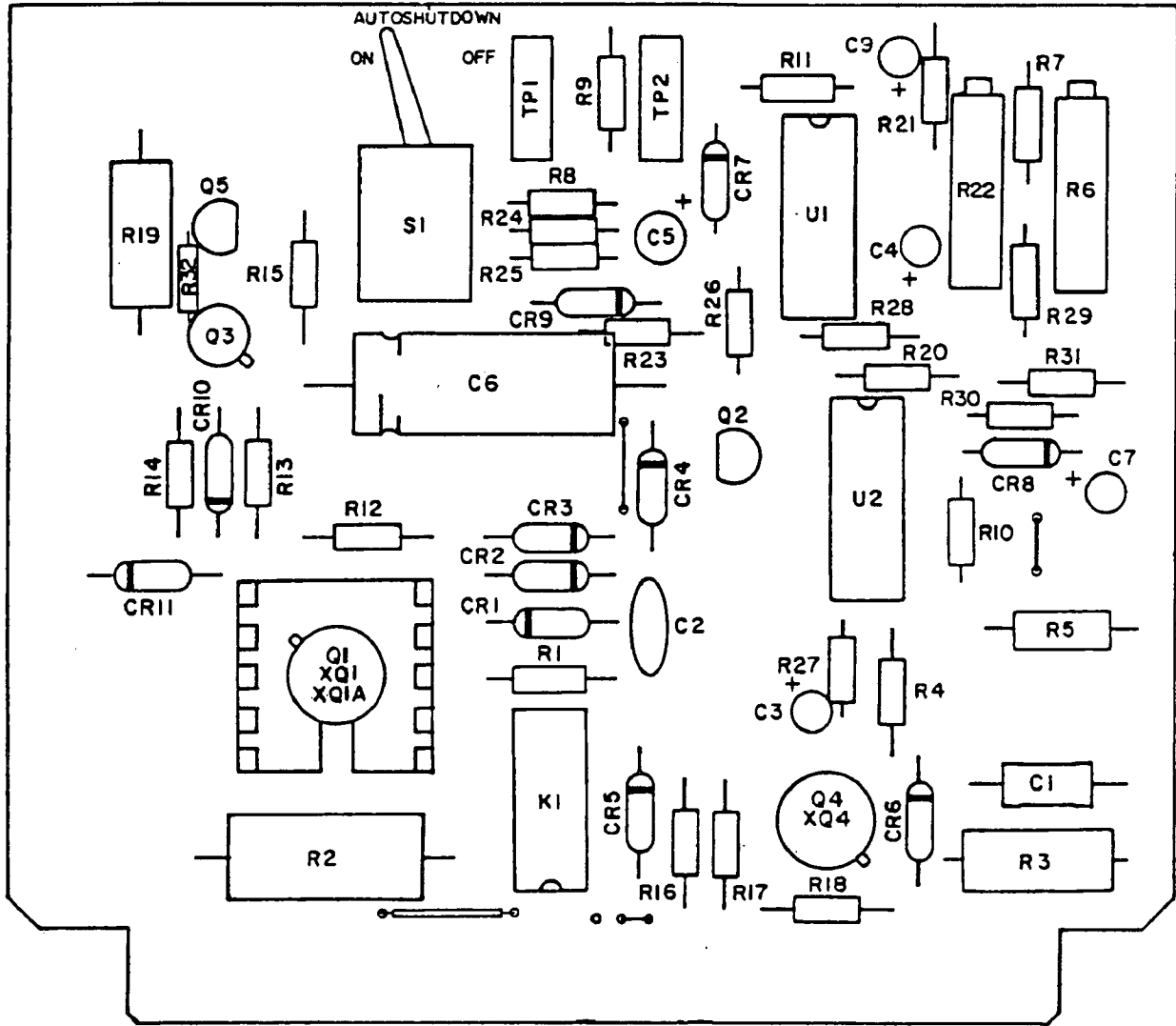

- NOTES: 1. THIS DRAWING NO. 2329 REV.D.
 TITLED: AM AUTO SHUTDOWN PWB 221-2329.
 2. SCHEMATIC DRAWING NO. 2328
 3. REF. DES. PREFIX
 4. PART NO. PWB 221-2329
 5. BOM 2329

AM AUTO SHUTDOWN PWB ASSEMBLY

2.2.10 Power Switch PWB Assembly

The Power Switch PWB Assembly allows current to pass through a transistor switch Q4, Q5 to the final transistors of a transmitter. The Power Switch PWB monitors the emitter current in each power transistor, and the overall supply current to the final amplifier stage. If an overall overcurrent condition is sensed, the transistor series switch Q4, Q5 is opened, removing power immediately from the final transistor collectors. The supply line from the Power Switch PWB to the final collectors is then shorted to ground by an SCR crowbar circuit. After about one second, power is reapplied to the final transistors. When the circuit is activated, an LED on the assembly will light indicating that power is being removed from the final transistors.

Overall high-current conditions are sensed by Q1. If current through R1, R2 exceeds approximately 25 Amps, Q1 begins to conduct, pulling pin 3 on U1 above the reference level set by R24 (approximately +3 VDC). Likewise, if any final transistor emitter current exceeds 3 Amps, the input signals to P2 from the transistor emitters will exceed the reference level. The output from comparator U1 will then go high, charging C12 and causing the U2 output to go high, followed by the U3 output going high. As the U2 output goes high the series transistor switch Q4, Q5 stops conducting. As the U3 output goes high, SCR Q9 is fired, discharging any charge remaining in the final amplifiers to ground. To return power to the final stage, the process is reversed.

2.2.11 Metering Circuit

The Metering Circuit provides measurements of RF output power, DC current in one of the final transistors, a tuning indication, and two DC voltage scales.

The RF power is measured by using a current transformer in the output circuit. The emitter volts measurement is a DC voltage measurement across one of the one ohm emitter resistors, and thus gives a direct measurement of DC current in the final transistors. Two voltage ranges are also provided for external measurements with a probe. A tuning indication is derived from a reflected power measurement in the antenna coupler.

METER PWB SCHEMATIC

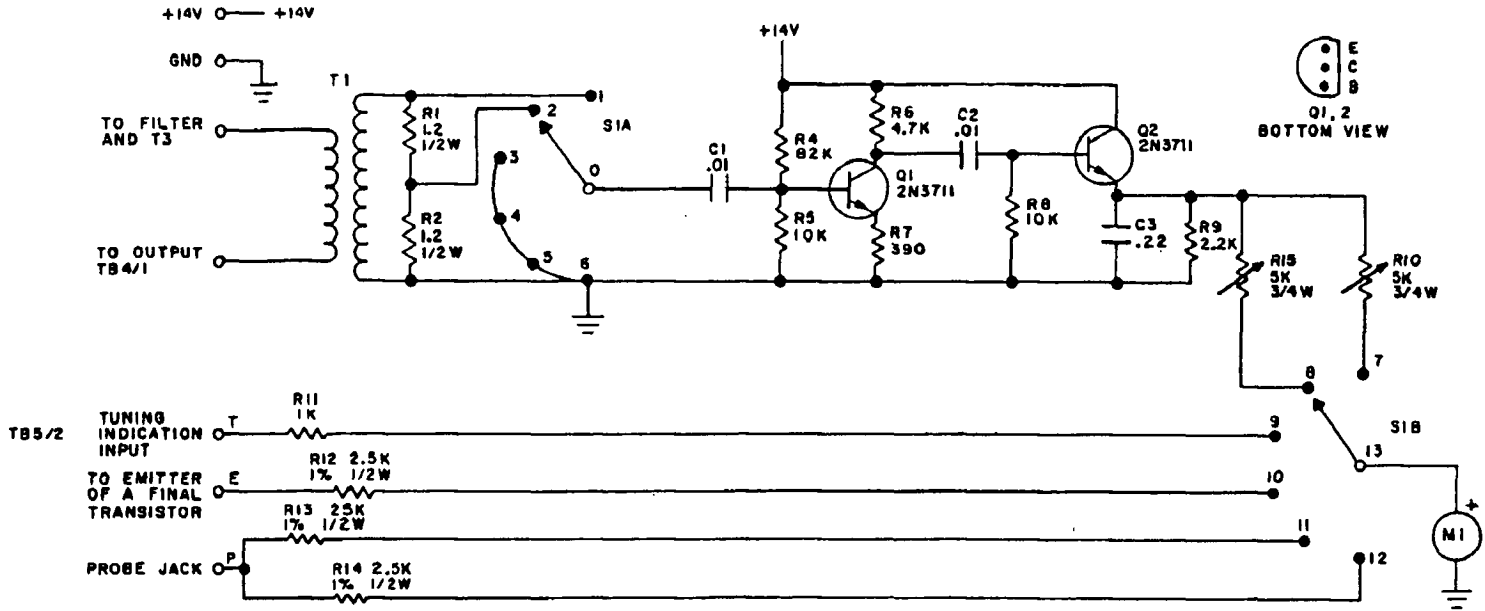

- NOTES: 1. THIS DRAWING NO. 1472 REV. A.
TITLED: METER PWB 123-1473 SCHEMATIC
2. ASSEMBLY DRAWING NO. 1473.
3. REF. DES. PREFIX A11.
4. ALL RESISTORS 1/4W, 10% UNLESS NOTED.
5. ALL CAPACITORS IN μ F UNLESS NOTED.
6. R3 NOT USED.

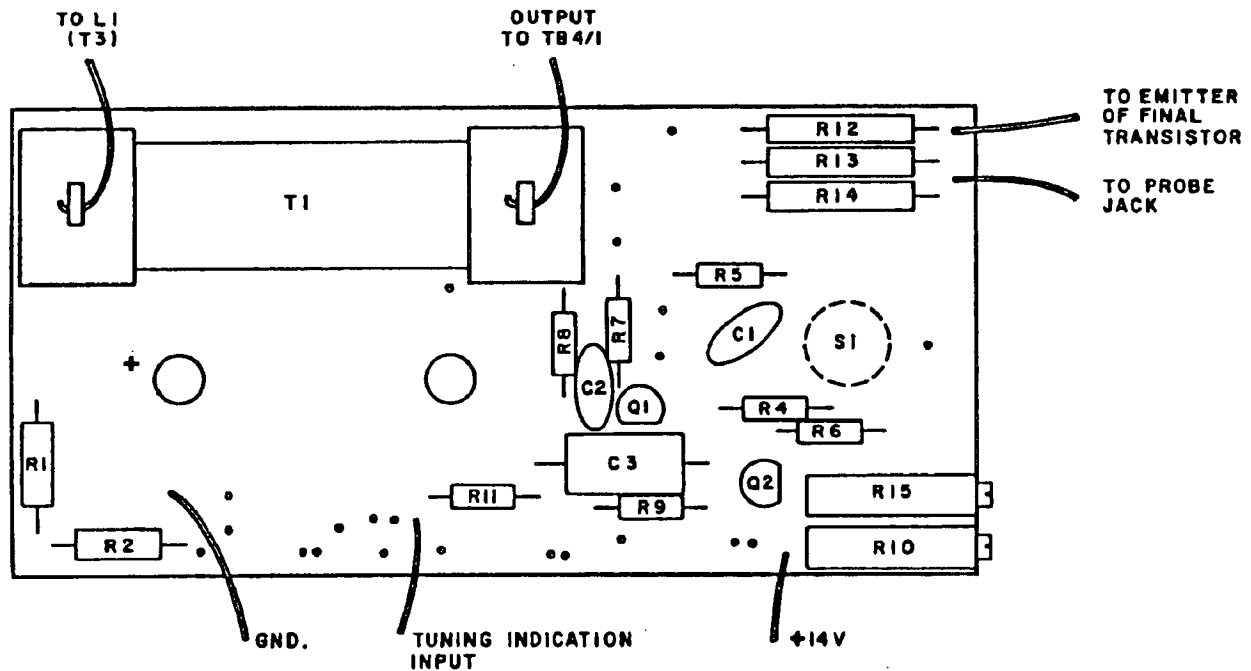

- NOTES: 1. THIS DRAWING NO. 1473
 TITLED: METER PWB 123-1473
 2. SCHEMATIC DRAWING NO. 1472 REV. A.
 3. REF. DES. PREFIX A11.
 4. PART NO. PWB 123-1473.
 5. S1 MOUNTED ON OTHER SIDE.
 6. R3 NOT USED.
 7. SEE BOM 1473 REV. A.
 8. C4 LOCATED ON SOLDER SIDE.

METER PWB ASSEMBLY

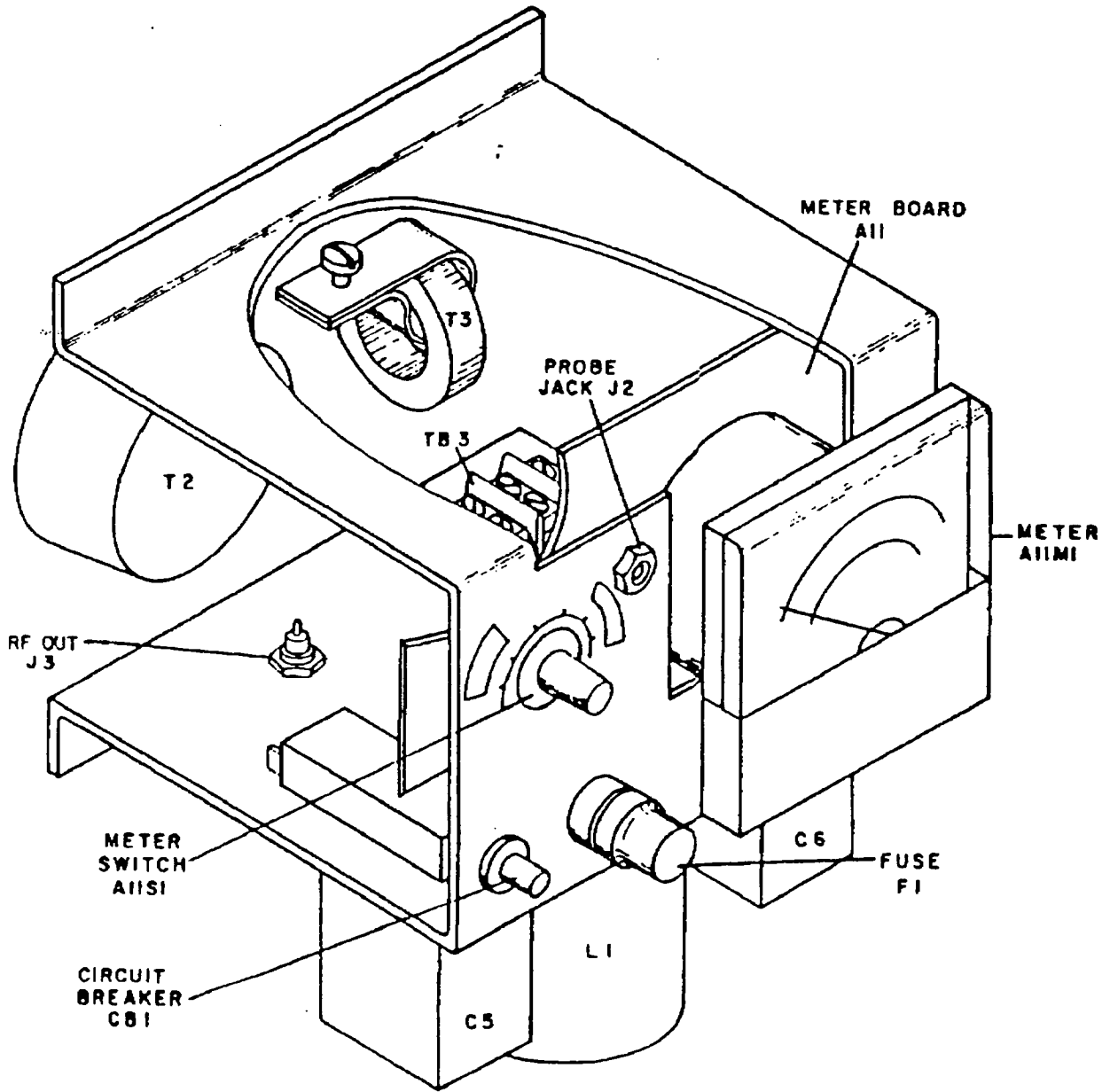

- NOTES 1. REF. DES. PREFIX 1.
 2. THIS DRAWING NO. 550 REV. B .

METER BRACKET ASSEMBLY

2.2.12 Reset SSC PWB

The Reset SSC PWB supplies a reset pulse to the Autoshtutdown PWB of an SSC series transmitter at 1 minute, 1 hour, 2 hours, and 3 hours following a shutdown of the NDB by the Autoshtutdown PWB. If the transmitter is still transmitting at one minute following a reset pulse, the Reset SSC PWB is cleared to its initial state, ready to supply reset pulses at 1 minute, 1 hour, 2 hours, and 3 hours following any new shutdown

If the transmitter stops transmitting within 1 minute following a reset pulse, the Reset SSC PWB waits until the next available reset time to apply a new reset pulse. If the transmitter has not successfully returned to proper operation and remained operating for at least one minute following the fourth reset pulse (3 hours after the original shutdown), the Reset SSC PWB is latched into a permanent shutdown mode which will remain until the circuits are manually reset by pressing the reset button on the Reset SSC PWB or power is momentarily removed from the transmitter.

Shutdown of the SSC transmitters is accomplished by SCR Q9 on the Autoshtutdown PWB being forced into a conducting condition by monitoring circuits on the Autoshtutdown PWB. As Q9 begins conducting, the voltage on the anode of Q9 will change rapidly from approximately 55 volts to approximately one volt. This negative-going signal passes through C1 on the Reset SSC PWB to U1A on the Reset SSC PWB. U1A and U1B form a set-reset flip-flop which is normally in an initial "reset" state, with the U1B output logic level = 0. This initial level maintains U2 in a reset state, with all outputs of U2 being a logic 0. When U1A detects a shutdown signal, the U1A/U1B flip-flop is changed to a "set" state with the U1B output logic level = 1. This will cause U2 to begin a binary counting of the R11, R12, C3-4 oscillator clock cycles. At one minute following the shutdown, U2 pin 5 will become logic 1. If U2 pins 4, 6, 14, 13, and 15 are all logic 0, U1D will then have a logic 1 on each of its inputs, causing the U1D output to go to a logic 0 and causing Q2 to stop conducting. Q1, which was not initially conducting, will be latched into conduction with the Q1 anode being pulled down to approximately 1 volt. C2, following shutdown was charged with +14V on the end attached to Q1 and 1 volt on the end attached to TB2 (6). When the Q1 anode end of C2 is forced to 1 volt as Q1 begins conducting, the end of C2 which is attached through TB2 (6) to Q9 of the Autoshtutdown PWB will force Q9 to be momentarily reverse-biased, stopping the Q9 conduction as soon as C2 is discharged. One minute following the reset of Q9, U2 pin 4 in the Reset SSC PWB will go high. If the transmitter has not shut down, TB2 (6) will be high (approximately +55V) and the U1A/U1B flip-flop

will be reset. If the transmitter has shut down, U1A/U1B will not reset and U2 will continue to count up to the next reset operation at approximately one hour.

Pressing the manual pushbutton S1 located on the Reset SSC PWB will cause both the reset circuits and the Autoshtutdown PWB to be returned to an initial "reset" state, with the transmitter operating.

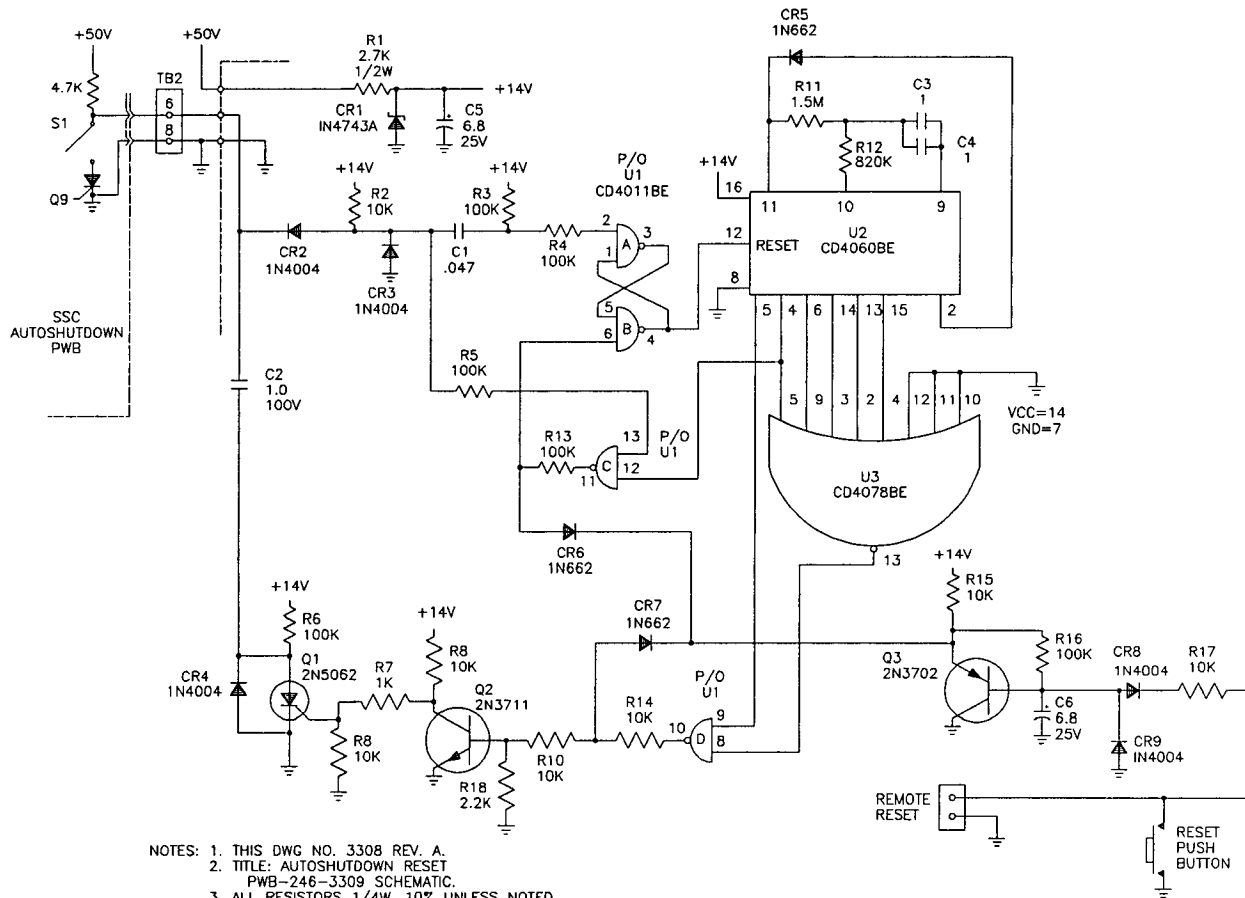

AUTO SHUTDOWN RESET PWB SCHEMATIC

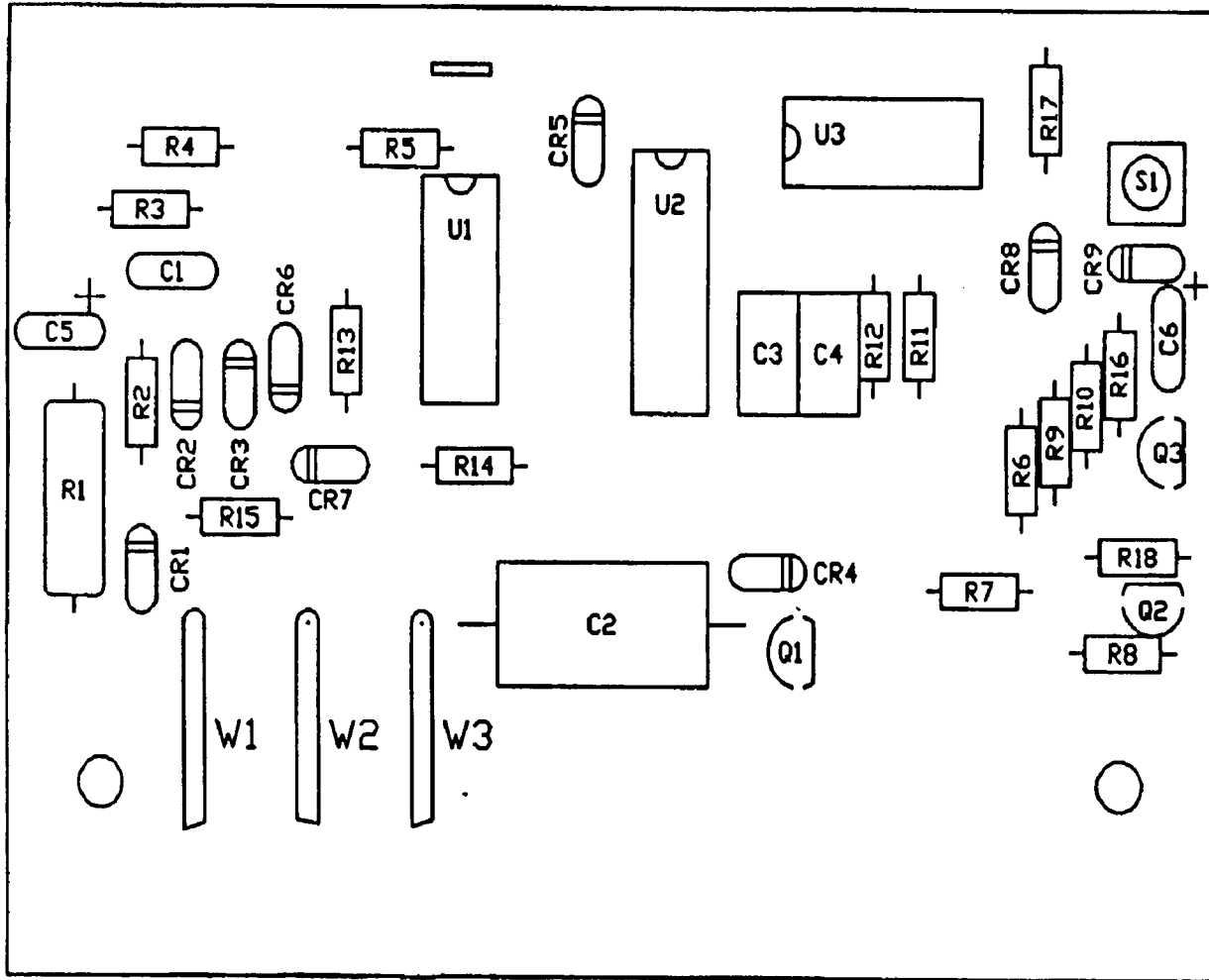

- NOTES: 1. THIS DWG NO. 3309 REV -,
 2. TITLE:
 RESET SSC PWB-246 ASSEMBLY.
 3. SCHEMATIC DWG NO. 3308.
 4. PART NO. PWB-246-3309.
 RESET SSC PWB ASSEMBLY

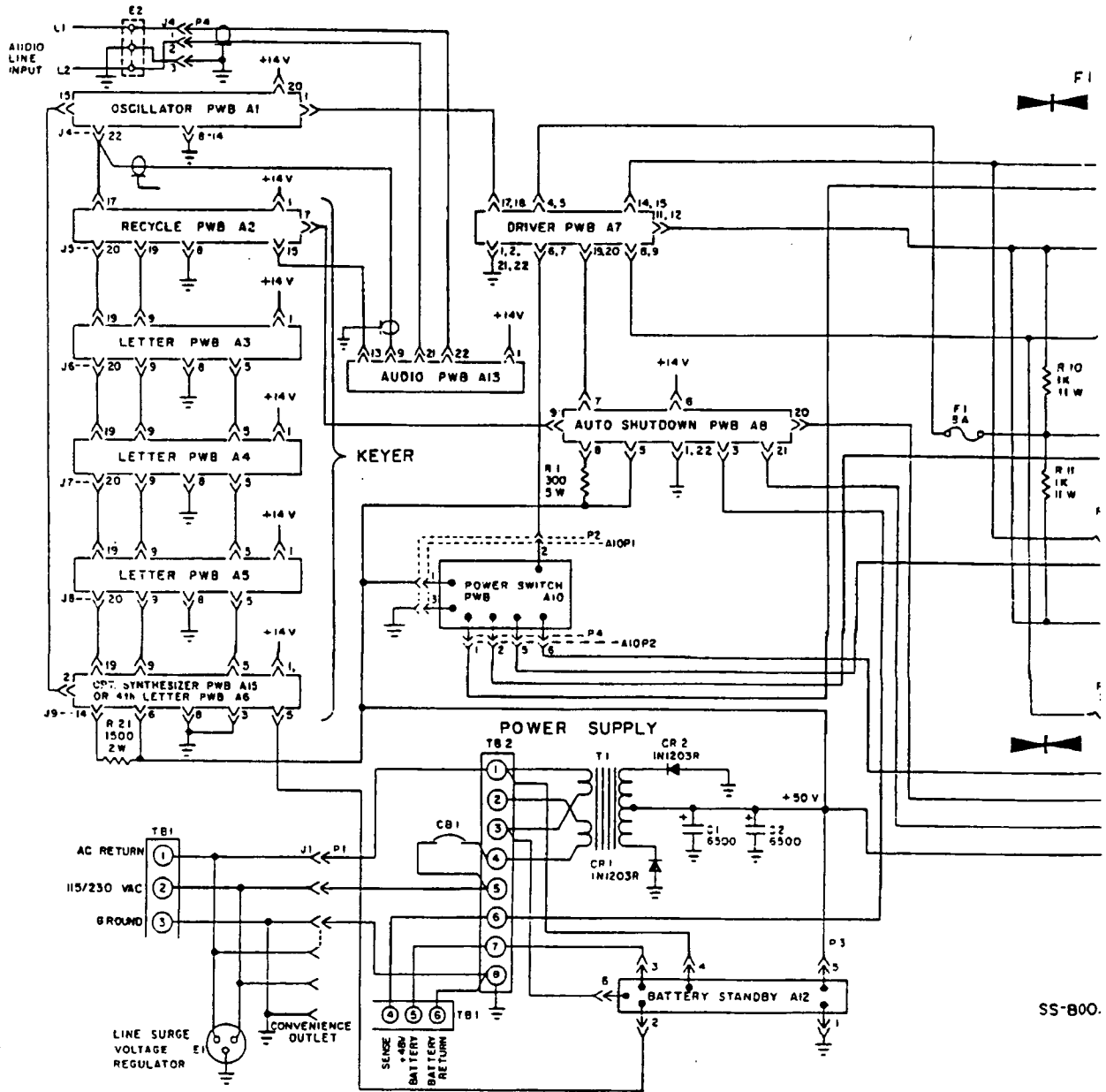

- NOTES
1. REF. DES. PREFIX 1
 2. ALL CAPACITORS IN MFD.
 3. ALL RESISTORS 1/2 W. VALUES IN OHMS
 4. THIS DRAWING NO. 677 REV G.

TRANSMITTER SCHEMATIC

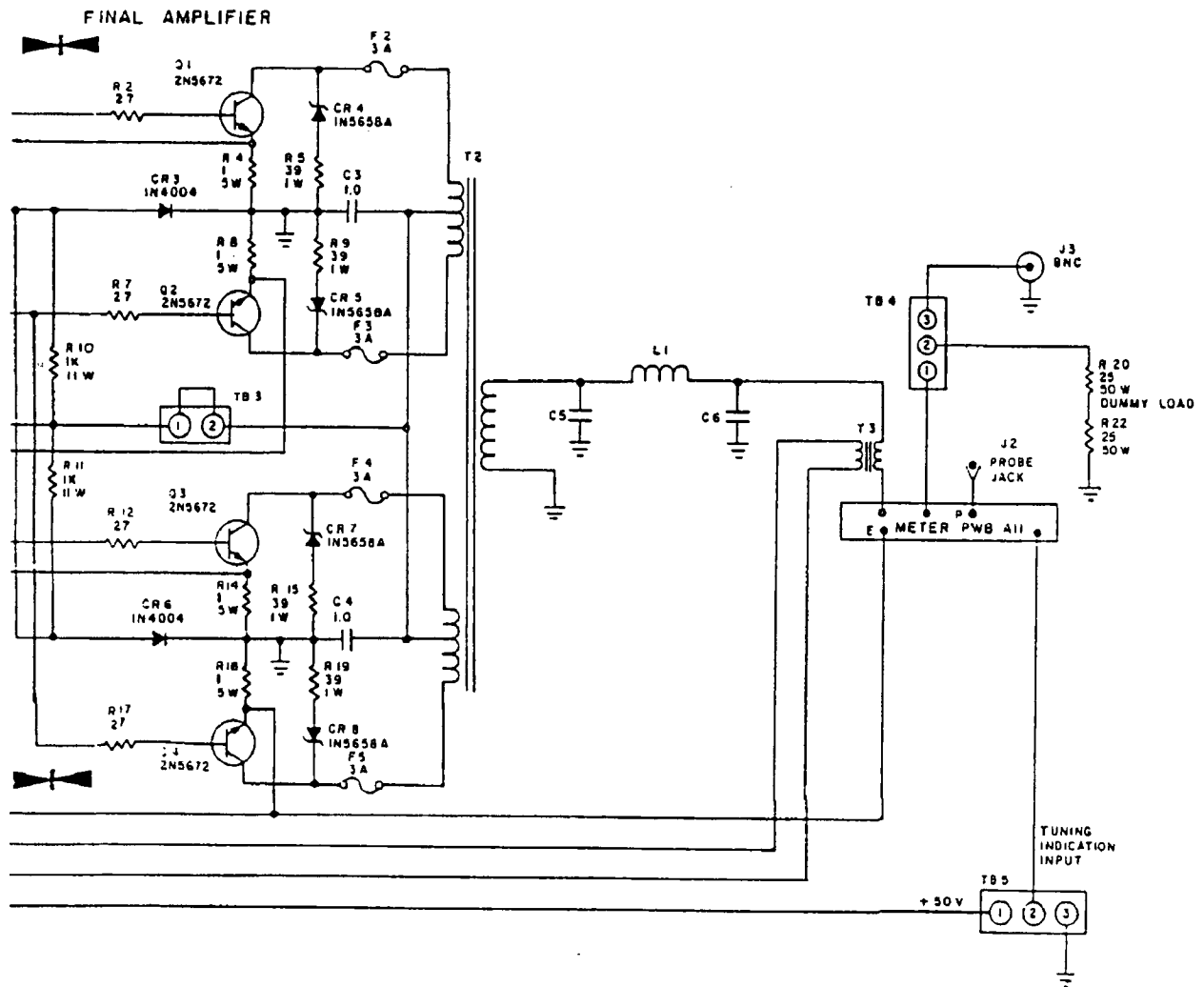
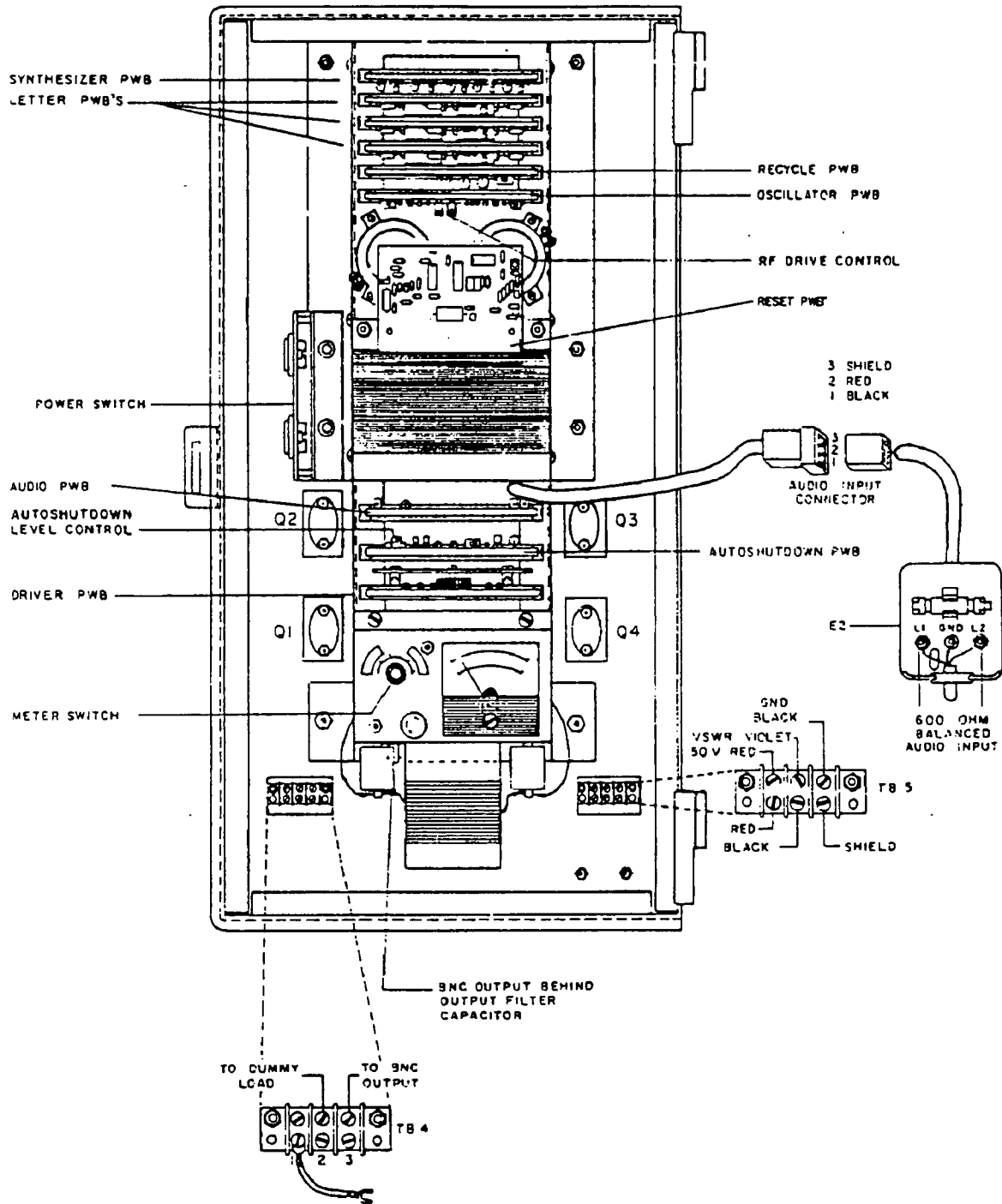

FIGURE 2-26

SS-800AV TRANSMITTER SCHEMATIC

f	C5, 6	L1
190-340 kHz	0.01	18 T
340-500 kHz	0.0068	14 T
500-625 kHz	0.004	11 T

TRANSMITTER SCHEMATIC (CONT.)



NOTE: 1. THIS DRAWING NO. 2174 REV C.

TRANSMITTER DIAGRAM

3 THEORY OF OPERATION, ANTENNA COUPLER

3.1 FUNCTIONAL DESCRIPTION: PC-1000B

3.1.1 Impedance Transformer

The impedance transformer matches the 50 ohm output impedance of the transmitter to any impedance from 2 to 25 ohms. The impedance transformation is chosen by selecting one of eleven taps in the transformer secondary.

3.1.2 Tuner

The tuner is a 240 turn coil with taps for coarse adjustment and a rotatable shorted turn for fine adjustment. Tuning range is from 22 uH to 3.6 mH which is sufficient to tune any practical antenna in the 190 - 625 KHz frequency range.

3.1.3 Autotune

The autotune circuit compares the phase of the voltage and current at the input to the coupler and turns the shorted ring in the tuner in the proper direction to tune the antenna system.

3.1.4 Antenna Current/Tuning Meter

This meter indicates antenna current in two ranges. It also detects reflected power to indicate tuning. The meter function is determined by a four position switch.

PC-1000 BLOCK DIAGRAM

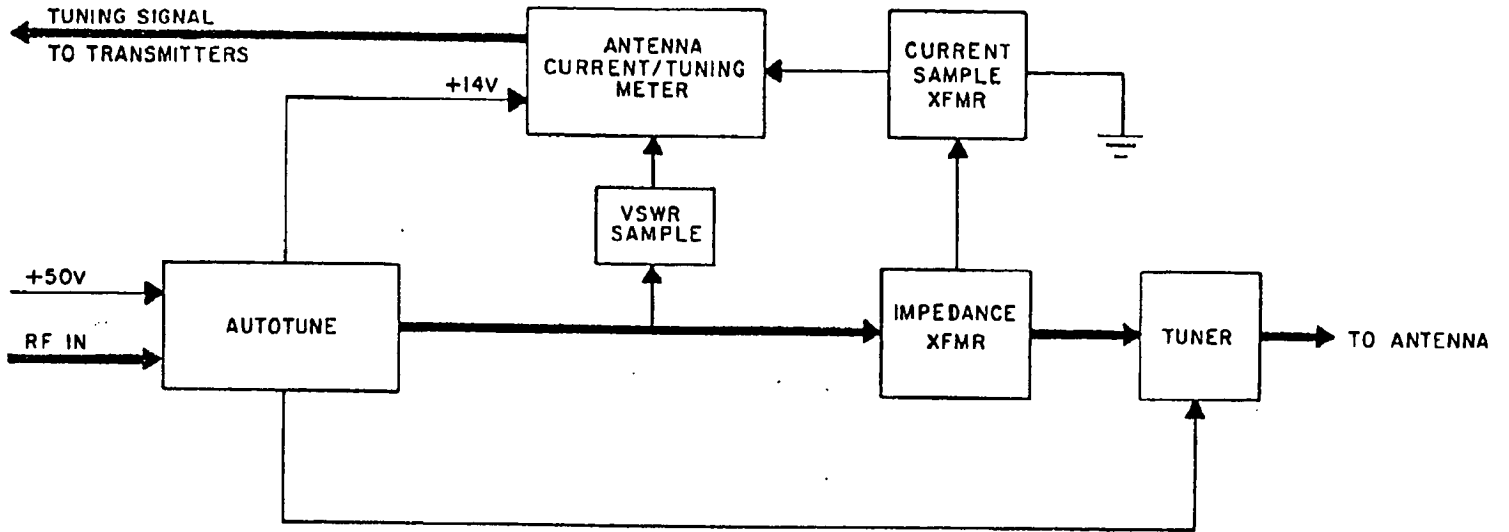

NOTES: 1. THIS DRAWING NO. 1028 REV. A.
TITLED: PC BLOCK DIAGRAM FOR SSC

3.2 DETAILED CIRCUIT ANALYSIS: PC-1000B

3.2.1 Impedance Transformers:

The impedance transformer is bifilar wound on a ferrite toroid. The secondary has 11 taps and is designed to transform a secondary load between 2 and 25 ohms to a 50 ohm input impedance. Tap selection is made with a switch on the front panel of the coupler. An air core transformer connected to the low potential end of the impedance transformer secondary samples the antenna current to provide a signal for the Antenna Current Meter.

3.2.2 Tuner:

This 240 turn coil has a transformer coupled shorted ring that can be turned manually or by the autotune motor. The 44 turns physically below the tuning ring are tapped every 4 turns for a fine tuning adjustment. The 200 turns above the tuning ring are tapped at 5 turns, 10 turns, 20 turns, and thereafter in 20 turn steps, to the top of the coil. The upper tap selection is made with a solder connection behind a removable panel. The lower tap selection is made with a switch on the front panel.

The autotune system automatically turns the tuning ring in a direction to tune the antenna system. If the correct taps have been chosen, the ring will stop when the system is tuned and change automatically when the system detunes due to changes in the antenna environment. If the correct tap has not been chosen, the tuning ring will move to a MAX or MIN limit and an LED indicator on the coupler front panel will indicate whether more or less inductance is needed. A manual knob for the tuning ring is also available on the coupler front panel. The tuning ring is capable of varying the total inductance approximately $\pm 5\%$ depending on the combination of taps.

Maximum inductance with the full coil is 3.5 mH ± 130 uH. Minimum inductance is 25 uH ± 3 uH. This is sufficient to tune a 200 to 1500 pF antenna from 190 KHz to 625 KHz. Tables are given showing the tuning range for SAC's Mast Antenna, Guyed Mast Antenna, and Symmetrical "T" Antenna.

PC-1000B ANTENNA COUPLER SCHEMATIC

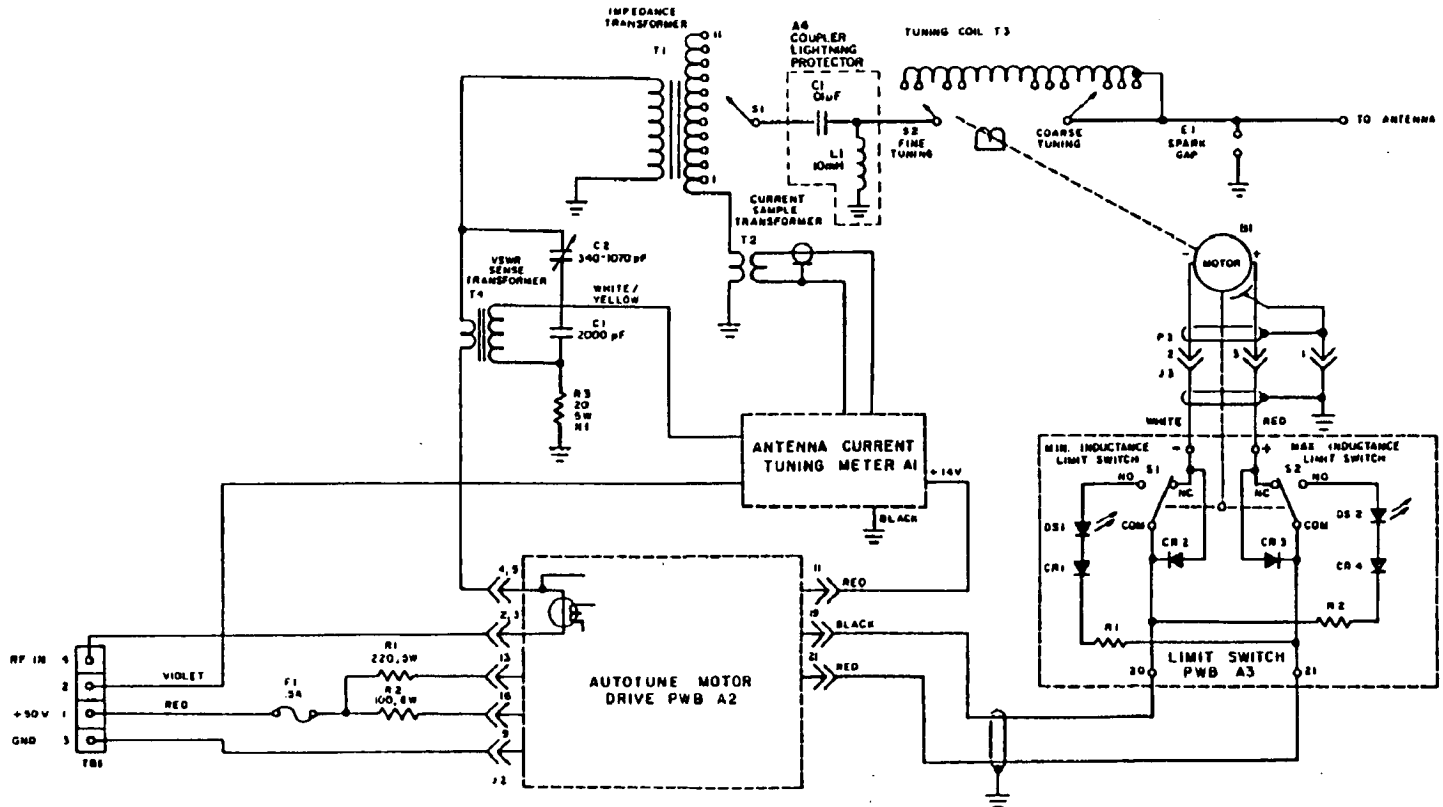

- NOTES: 1. THIS DRAWING NO. 1042 REV. C.
TITLED: PC-1000 ANTENNA COUPLER SCHEMATIC
2. REF. DES. PREFIX 2.
3. USED ON: SS-500, SS-500V, SS-500VS, SS-500MV, SS-500MVS
 SS-800A, SS-800AV, SS-800AVS, SS-800MV, SS-800MVS
 SS-1000, SS-1000A, SS-1000AS, SS-1000M, SS-1000MS
 SS-1000AS

3.2.3 Autotune

The autotune system is an electronic antenna tuning system located in the antenna coupler and comprises the Autotune Motor Drive PWB, the Limit Switch PWB, and the Tuning Motor and Tuning Ring Assembly. The relative phase of the current and voltage signals to the 50 ohm RF input of the coupler are compared by electronic circuits to determine if the antenna is tuned inductive, resistive, or capacitive. A properly tuned antenna system is considered to have a zero relative phase difference between voltage and current. As the system changes so that the load exhibits reactive components, whether inductive or capacitive, no retuning action will be taken until the phase magnitude exceeds a level determined by the tolerance adjust control (R16) on the Autotune Motor Drive PWB. When this level of phase error is exceeded, the logic circuits will activate the tuning motor in the proper direction to return the system to a resistive load state. Motor drive continues until a relative phase change is detected, indicating passage of tuning through a resistive state. Circuits on the Autotune Motor Drive PWB prevent any tuning action during periods of low or no input signals, during transmitter ident, and when the Setup/Run Switch (S1) is in the Setup position.

RF current from the transmitter passes through T1 of the Autotune Motor Drive PWB. Limiting amplifiers U1 and U2 amplify and square the current and voltage signals and feed them into U3 for determination of the magnitude of the phase difference between the current and voltage signals. The output of U3, pin 11, is filtered by R12 and C10 to produce a DC voltage at TP1 (Brown) proportional to the phase difference. The DC voltage is compared by voltage comparator U5 with a reference voltage at TP2 (Red) set by the tolerance adjust control (R16). As the TP1 voltage becomes more positive than the TP2 voltage, the output of U5, pin 7, changes from 0 V to 14 V to indicate an out of tolerance antenna tuning condition. The tolerance limit set by the tolerance adjust control (R16) is adjustable to accommodate different antenna and frequency conditions. U3 outputs at pins 3 and 4 are compared by type D flip-flop U4 to determine whether the current signal is leading or lagging the voltage signal. If the voltage signal is leading the current signal as with an antenna tuned to the inductive side of resonance, the data input, pin 2 of U4, will become positive just before the positive transition of the clock input, pin 3. On the positive clock transition, the Q output, pin 5, of U4 is latched into the same state as the U4 data input, pin 2, with a logic 1 (14 V) indicating an inductive antenna condition. This condition is also indicated by LED DS1. As the U5 output, pin 7, changes from 0 V to 14 V, to signal an out of tolerance tuning condition the positive transition will cause the antenna condition to be latched at U4, pin 9, and through the logic of U7 will determine the motor drive direction. The U5 output,

pin 7, also latches the flip-flop contained in U6, into drive state, with a logic 0 (0 V) at U6 pin 3. If the Setup/Run Switch (S1) is in the Run position, if the input signals are high enough to trigger Q1, and if no ident signal is present to trigger Q3, the motor will be activated with 14 V at U7 pin 10, and 0 V at U7 pin 6. DS2 will light, and the motor will rotate to decrease the inductance of coupler transformer T3.

Rotation will continue until the logic signals at pins 8 and 9 of U3 differ, indicating that the antenna tuning has transitioned from an inductive to a capacitive condition. The motor halts with the U6 flip-flop reset until an out of tolerance condition is again sensed.

AUTOTUNE MOTOR DRIVE PWB SCHEMATIC

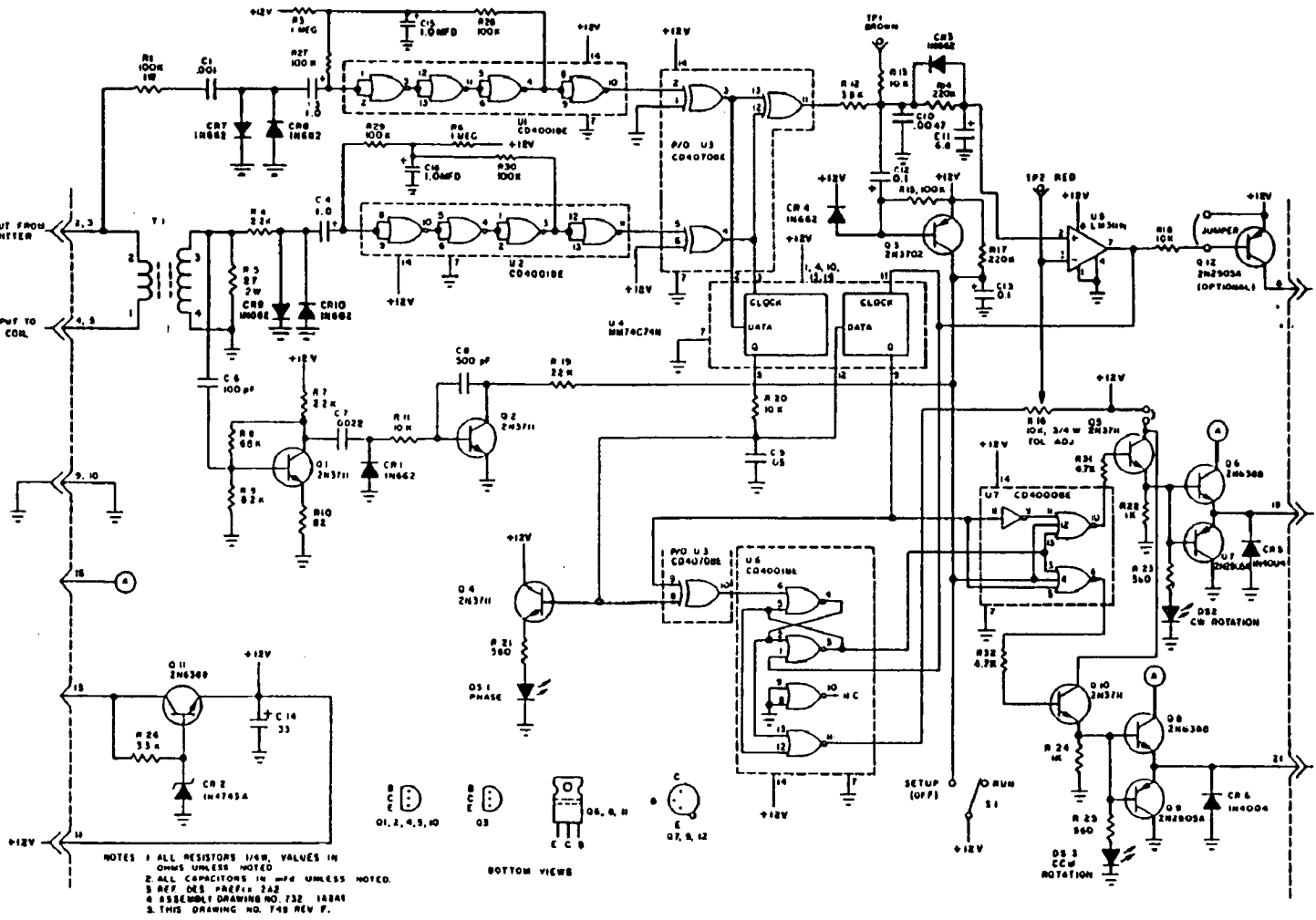

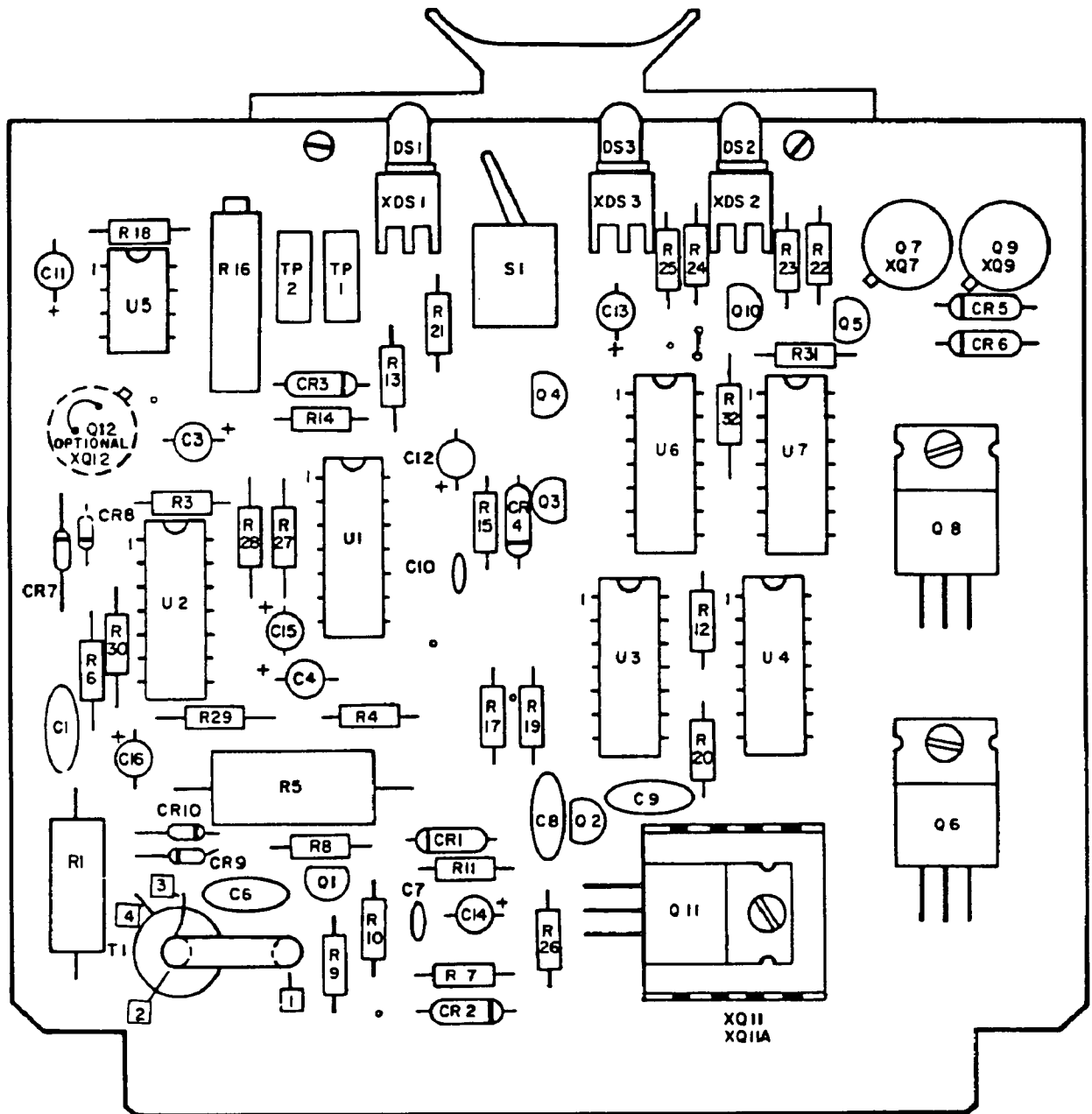

NOTES: 1. REF. DES. PREFIX 2A2, 1A2A1
 2. THIS DRAWING NO. 2909 REV. A
 3. SCHEMATIC DRAWING NO. 749
 4. TITLE: AUTOTUNE MOTOR DRIVE PWB-142-732 DIAGRAM.
 AUTOTUNE MOTOR DRIVE PWB ASSEMBLY

3.2.4 Antenna Current/Tuning Meter

The RF signal from the current sample transformer is developed across R1 and R2, amplified by Q1 and detected by Q2. The detected signal is calibrated with R10 and R11 and fed to the 1 mA meter.

An RF signal proportional to reflected power is generated by T4 and C2 in the antenna coupler and fed to Q3 on the Antenna Current/Tuning Meter PWB for detection. The detected signal is fed through R12 to the 1 mA meter.

ANTENNA CURRENT/TUNING METER PWB SCHEMATIC

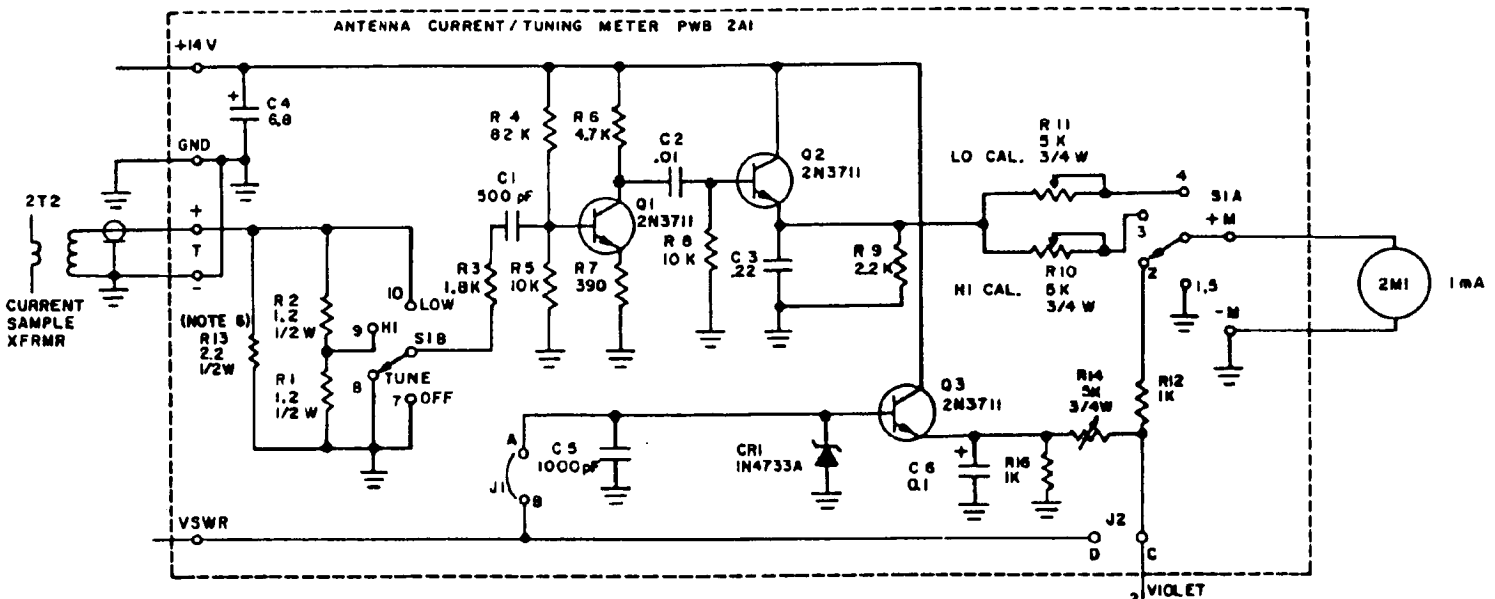

- NOTES: 1. REF DES. PREFIX 2A1
 2. THIS DRAWING NO. 646 REV. G.
 3. ASSEMBLY DRAWING NO. 641.
 4. ALL RESISTORS 1/4 W, UNLESS NOTED.
 5. ALL CAPACITORS IN MFD, UNLESS NOTED.
 6. R13 NOT USED ON PC-1000A.
 7. TUNING INDICATION OUTPUT NOT USED ON PC-3000.
 8. TITLED: ANTENNA CURRENT / TUNING METER PWB SCHEMATIC

(NOTE 7) 2 VIOLET
 P/O TB1
 TUNING INDICATION OUTPUT



Q1-3
BOTTOM VIEW

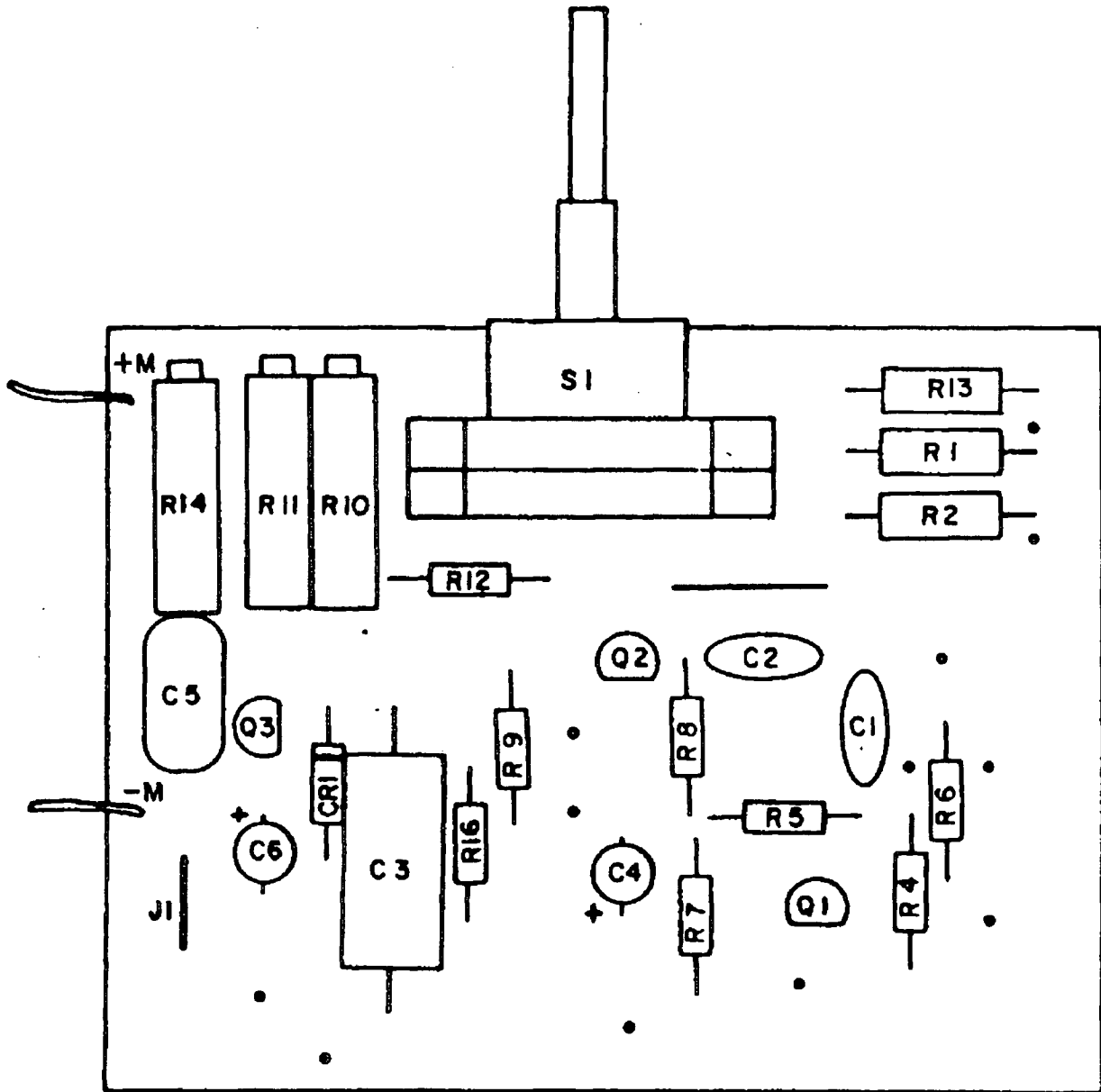

- NOTES: 1. THIS DRAWING NO. 2083 REV. B.
 TITLED: ANTENNA CURRENT/TUNING
 METER PWB 118-641
2. SCHEMATIC DRAWING NO. 646 REV. G.
3. PART NO. PWB 118-641.
4. REF. DES. PREFIX 2A1.
5. SEE PARTS LIST 2083.
- ANTENNA CURRENT/TUNING METER PWB ASSEMBLY

4 ANTENNAS

The range of a beacon and antenna depends on many variables and cannot be guaranteed. The field strength can be calculated if the ground conductivity is known, but the field strength needed depends on the background environmental noise which depends on location. A field strength of $70\mu\text{V}/\text{m}$ is generally adequate in the United States and Europe but may not be sufficient in latitudes between 30°N and 30°S . Range figures given in the following sections are based on average ground conductivity and a field strength of $70\mu\text{V}/\text{m}$.

The resistance of the antenna is dependent on many conditions over which the manufacturer has no control. The ground condition, for example, is extremely important. In a high conductivity ground region, the resistance will be fairly low. This is especially true on offshore oil rigs where the ground system consists of a large metal structure over salt water. On the other hand, if the ground conductivity is low, the resistance can become quite large. For example, permafrost in Alaska generally makes a very poor ground and in most cases a special counterpoise system must be used. Without a special counterpoise system, the antenna resistance may be as high as 50 ohms and the antenna efficiency will be very low.

THE MAST ANTENNA, "H" ANTENNA, AND 50-FOOT GUYED MAST ANTENNA ARE HIGH Q, NARROW BANDWIDTH ANTENNAS. THEY SHOULD NOT BE USED FOR VOICE MODULATION. THE SYMMETRICAL "T" ANTENNA IS THE ONLY ANTENNA RECOMMENDED FOR VOICE MODULATION.

4.1 Mast Antenna

The Mast Antenna is a short vertical monopole with capacitive top loading and inductive center loading. It was designed for use where space is severely limited such as on offshore structures. It is centerloaded to be resonant at approximately 500 KHz for operation between 190 and 415 KHz and at approximately 900 KHz for operation between 415 and 625 KHz. Tuning below the resonant frequency is accomplished with the antenna coupler. There are two versions of this antenna; one designed to be mounted on land, the other on drilling platforms or ships. Neither antenna requires guying. A capacitive hat at the top of the 34-foot Mast Antenna consists of six 8-foot radials. These can be shortened if necessary for clearance on drilling platforms. The counterpoise system used for land installations consists of sixteen 60-foot radials made of #10 copper wire with 6-foot ground rods at each end and one in the center. The offshore version of the Mast Antenna uses the platform structure and the water for the ground system.

The range with the Mast Antenna and this transmitter depends on ground condition, frequency, the ADF, and atmospheric noise which in turn depends on location and time. Range for most locations in the United States with one of the lower priced ADF's is from 50 to 70 miles for frequencies above 250 KHz except over low conductivity ground. SAC does not recommend this antenna for land installations at frequencies below 250 KHz. The "T" Antenna is far superior at all frequencies and should be used whenever space permits. The 50-foot Guyed Mast is recommended for land installations where the "T" cannot be used. Calculated range over sea water with the Mast Antenna and this transmitter is 40 miles at 200 KHz, increasing to 100 miles at 400 KHz.

Ideally, this antenna should be in a clear area; however, this is very seldom feasible on offshore structures. Large obstacles close to the antenna will affect the directional properties and the tuning of the antenna. If possible, the antenna should be installed with a clear area in the direction of the most traffic.

The Mast Antenna is electrically very similar to a 200 pF capacitor in series with a small resistor. See the figure at the end of this section for a plot of the capacitive reactance.

4.2 "H" Antenna

The "H" Antenna is used on the helipad of offshore structures where there is no clear area to install the Mast Antenna. It is a wire structure that is installed on the perimeter of the helipad. The transmitter is mounted directly beneath it so that the vertical portion of the antenna is the offshore structure itself. Electrical characteristics vary, depending mostly on the size of the helipad but are generally similar to the Mast Antenna. Range is also comparable with the Mast in most cases.

4.3 50-Foot Guyed Mast Antenna

This antenna is a guyed vertical monopole with capacitive top loading that was designed for land installations where space is limited. The capacitive top hat consists of six 8-foot radials. The counterpoise system consists of sixteen 60-foot radials made of #10 copper wire with 6-foot ground rods at each end and one in the center. The antenna is guyed at the top and center.

The calculated range with the Guyed Mast Antenna exceeds the Mast Antenna but is less than the "T" Antenna under the same conditions. This antenna is recommended for land installation where space does not permit use of the "T" Antenna.

The Guyed Mast Antenna is electrically very similar to a 300 pF capacitor in series with a small resistor. See the figure at the end of this section for a plot of the capacitive reactance.

4.4 Symmetrical "T" Antenna

The Symmetrical "T" Antenna is recommended if sufficient land is available. This antenna requires a plot of ground approximately 150 feet by 350 feet.

The calculated range with the "T" Antenna and this transmitter for most locations in the United States and with one of the lower priced ADF's is from 80 to 100 miles except over low conductivity ground.

These range figures are for the standard "T" Antenna with a height of 55 to 60 feet. A long range "T" Antenna with a height of 80 to 85 feet has a range of 100 to 120 miles. If even more range is desired, SAC can supply "T" Antennas with heights up to 200 feet.

The standard "T" is electrically very similar to a 1000 pF capacitor in series with a small resistor. See the figure at the end of this section for a plot of the capacitive reactance.

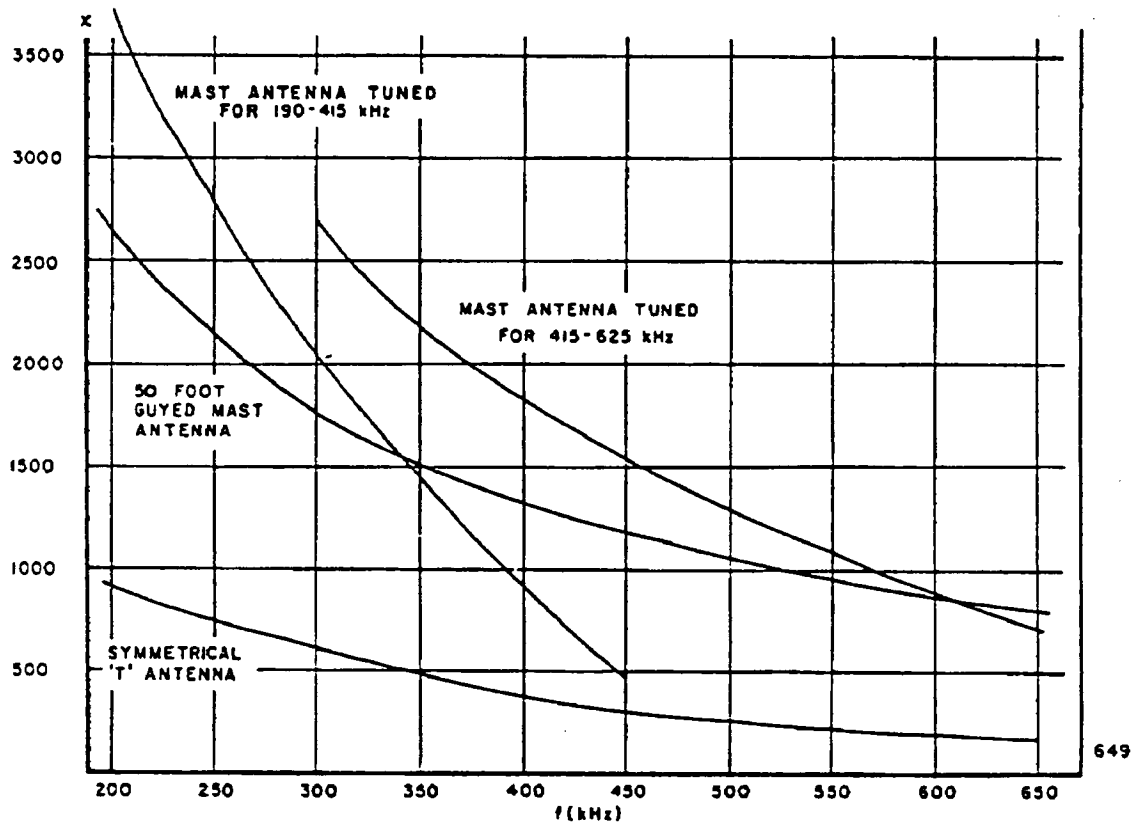

NOTE: THIS DWG. NO. 1031.

ANTENNA REACTANCE

5 INSTALLATION AND OPERATION

For security and/or safety, it may be desirable to enclose the transmitter in a building, and/or to enclose the transmitter and antenna site with a fence. A grounded metal building and a grounded metal fence are preferred. If wood or some other absorbent material such as concrete blocks or brick is used, it must be sealed so that it cannot absorb moisture. An absorbent structure close to the antenna will cause the antenna resistance to increase when the structure absorbs moisture. This will cause the antenna current to decrease and, in an extreme case, can activate the automatic shutdown system.

5.1 Transmitter Installation

1. Mount the equipment according to the Equipment Installation Manual.
2. Attach the ground wire from the counterpoise system or offshore platform to the copper ground lug(s) on the transmitter(s).
3. Make all connections according to the Equipment Installation Manual and the 50V Power Supply Schematic, Assembly and the Transmitter Schematic and Diagram in section 2. DO NOT APPLY POWER AT THIS TIME.
4. Connect the jumper on each transmitter TB4 from terminal 1 to terminal 3.
5. Check that the straps on the power transformer terminal block TB2 are correct: terminals 1 to 2, 3 to 4 for 115 VAC, terminals 2 to 3 for 230 VAC. See drawing for "50 V Power Supply Schematic".
6. If the optional Battery Standby system is installed, place the ON/OFF switch on the Battery Standby system in the OFF position. Run the battery cables from TB1 terminal 5 (+48V battery) and terminal 6 (Battery Return) to the storage batteries. Connect the batteries for 48 volt operation and attach the +48V and Battery Return cables to the corresponding battery terminals.
7. If the optional Audio PWB is installed, connect the balanced audio line input to the two outer screws of the audio line input protector E2.

NOTE: Do not remove the shield over the Oscillator and Keyer section unless the transmitter is operating into the dummy load. The large RF field in the vicinity of the antenna will interact with the Oscillator and Keyer section creating spurious responses.

5.2 Coupler Setup

1. Mount the coupler to the H-Beam, tower legs, or offshore platform with the appropriate supplied hardware. See Equipment Installation Manual.
2. Remove the access panel located above the tuning controls panel.
3. Locate the antenna feedthrough insulator bushing, and carefully insert into the glass insulator panel according to the instruction sheet packaged with the insulator. Do not over tighten or stress the insulator components. Locate the rainshield and install according to the enclosed directions.
4. Connect the wire from the top of the coil assembly in the coupler to the insulator bushing. Attach the antenna lead to the external end of the insulator bushing. Dress all leads at least 2 inches from metal surfaces.
5. Locate and install the lightning arrestor with the two screws located between the insulator bushing and the front access door. Adjust the spark gap if necessary to approximately 1" (2.5 cm).
6. Connect the cables according to the, "Antenna Coupler Cable Connections," and "Transmitter Diagram." (See table of figures.)
7. Attach the ground wire from the counterpoise system or offshore platform frame to the copper ground lug on the coupler.
8. Set all taps according to the following table and charts in this section. Fine tuning taps are chosen with a front panel switch. The coarse tap is chosen by connecting a clip lead to the proper coil tap behind the coil access panel. A permanent connection will be made later. Set the Setup/ Run switch on the Autotune PWB to Run.

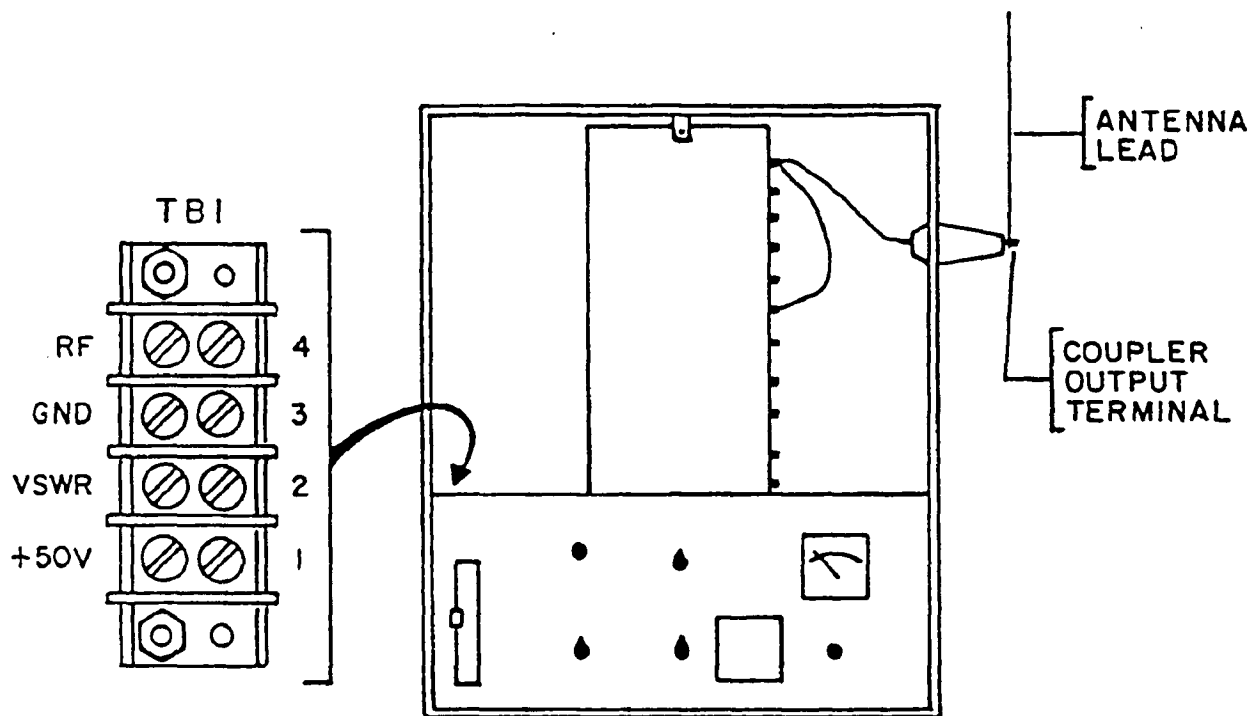

NOTES: 1. THIS DRAWING NO. 2327 REV. A.

* 2. TERMINAL 4 OF TBI MAY BE REPLACED BY EXTERIOR TYPE N CONNECTOR ON SOME UNITS.

ANTENNA COUPLER CABLE CONNECTIONS

f(kHz)	MAST ANTENNA	50 FOOT GUYED MAST	"T"
190-220	9	7	5
220-250	8	7	4
250-290	7	6	4
290-625	6	6	4

NOTES: 1. THIS DRAWING NO. 1022.

IMPEDANCE TRANSFORMER TAPS

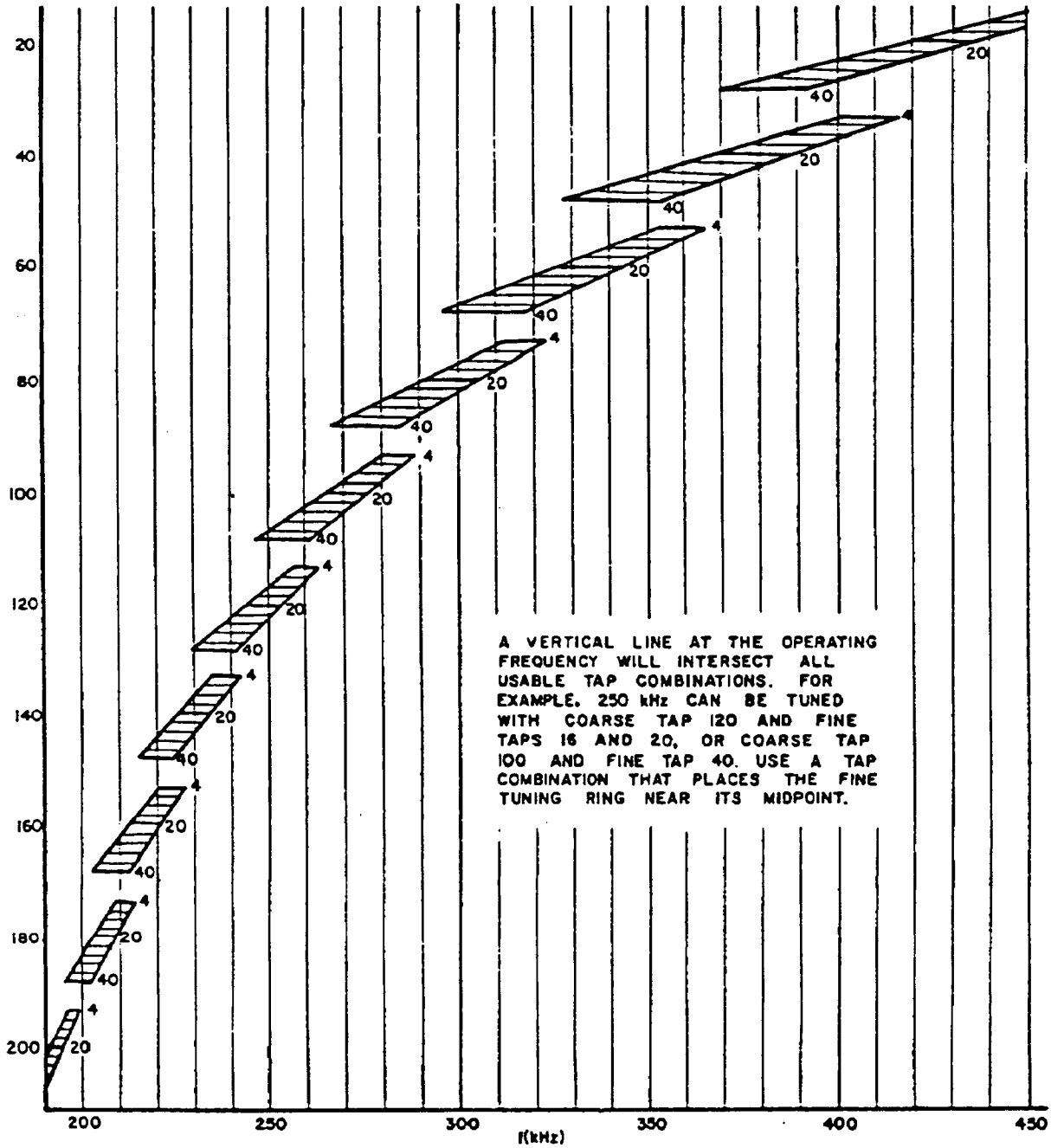

NOTE: 1. THIS DRAWING NO. 426 REV. A.

MAST ANTENNA AND PC-1000
 MAST TUNED FOR 190-415 KHZ

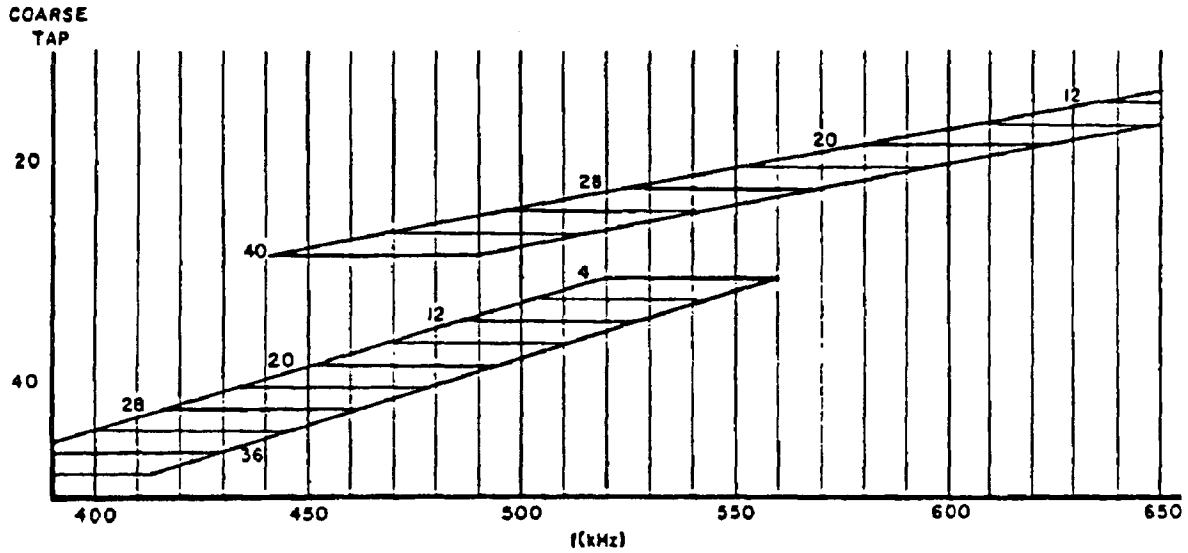

NOTES: I. THIS DRAWING NO. 1023.

A VERTICAL LINE AT THE OPERATING FREQUENCY WILL INTERSECT ALL USABLE TAP COMBINATIONS. FOR EXAMPLE, 450 kHz CAN BE TUNED WITH COARSE TAP 40 AND FINE TAPS 20, 24, AND 28 OR COARSE TAP 20 AND FINE TAP 40. USE A TAP COMBINATION THAT PLACES THE FINE TUNING RING NEAR ITS MIDPOINT.

MAST ANTENNA AND PC-1000
 MAST TUNED FOR 415-625 KHZ

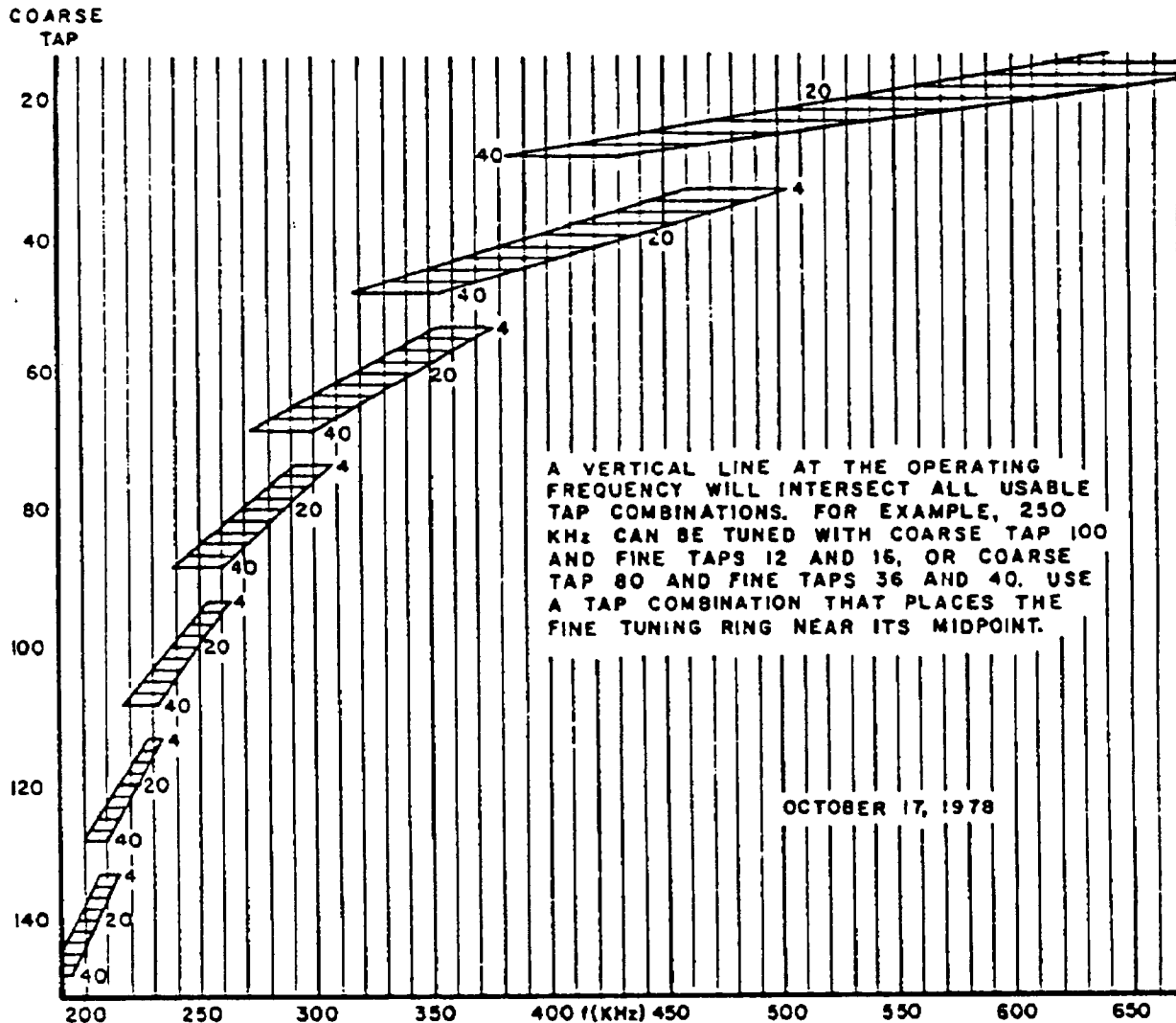

NOTES: 1. THIS DRAWING NO. 1025 REV. A.

50 FOOT GUYED MAST AND PC-1000

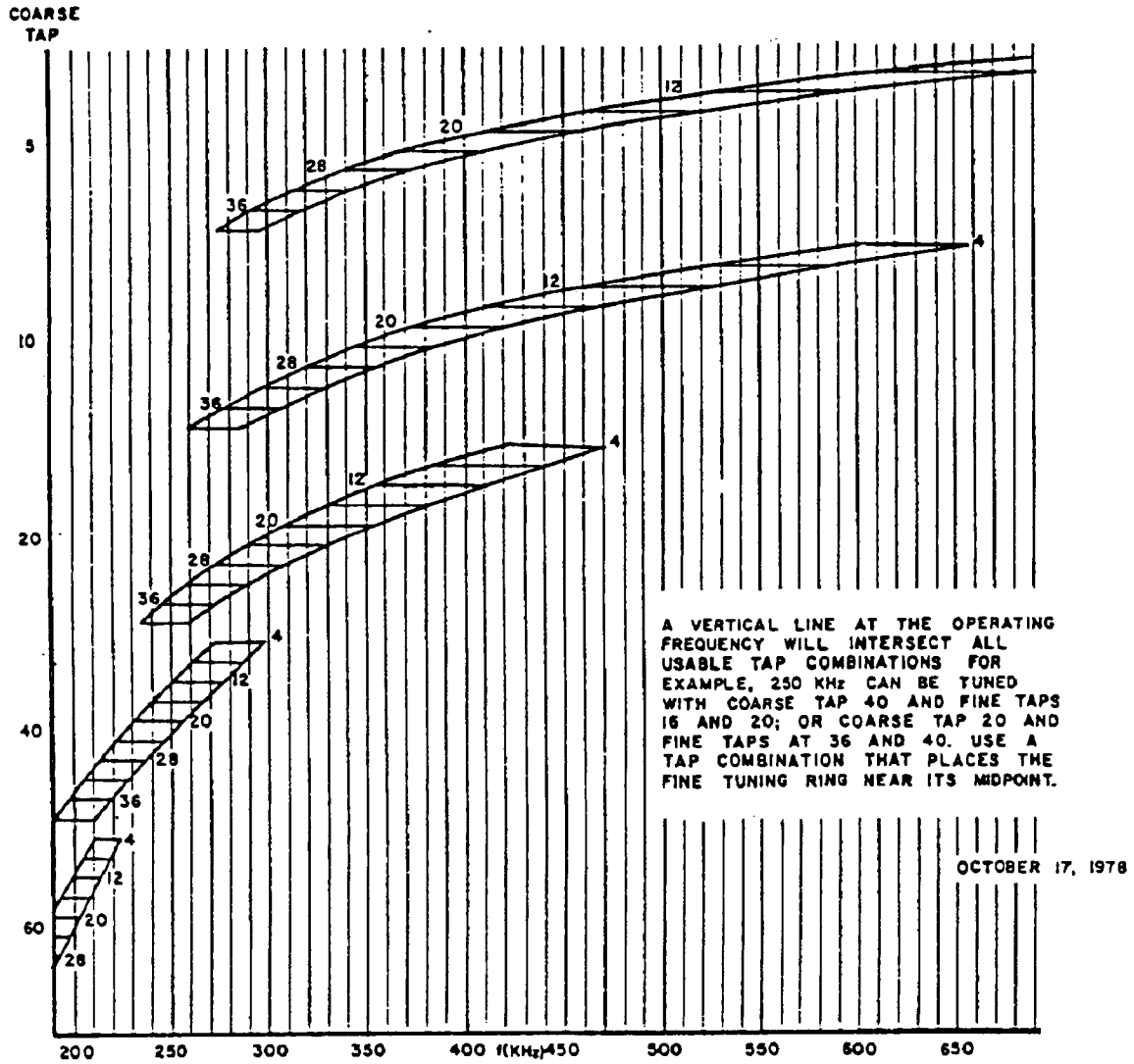

NOTES: 1 THIS DRAWING NO. 1024 REV. A.

SYMMETRICAL "T" ANTENNA AND PC-1000

5.3 Synthesizer Adjustment

If a frequency was assigned, all adjustments have been made at the factory. If no frequency was assigned, or if a change in frequency is made, the following procedure should be completed.

1. Select the correct AM Oscillator PWB, Synthesizer Programming PWB, and RF Output Filter according to the following table of Synthesizer Bands.
2. Rotate the programming switches to the desired operating frequency. See drawing for "Synthesizer PWB Assembly". For example, to select 250 KHz, rotate S1 to 2, rotate S2 to 5, and rotate S3 to 0. S4-1 and S4-2 should both be OFF. For 250.5 KHz, place S4-1 in the ON position. For 1250.5 KHz, place S4-2 and S4-1 in the ON position.
3. Attach a voltmeter to TP4 (Error Voltage) and TP1 (Ground). For best results, the voltmeter should be a high-impedance digital voltmeter, however, satisfactory results may be obtained with a 20,000 ohm/volt VOM.
4. Check that the RF DRIVE control on the AM Oscillator PWB is fully CCW. Connect the jumper on TB4 from Terminal 1 to Terminal 2.
5. Apply power to the transmitter.
6. Note the voltmeter reading. If the voltmeter reads 0, the LC oscillator is tuned above the selected frequency and beyond the phase-lock capture range. If the voltmeter reads approximately 8.5 to 9 volts, the LC oscillator is tuned below the selected frequency and beyond the phase-lock capture range. If the voltage is between 0.5 volts and 8 volts, the LC oscillator is locked to the reference oscillator and is on the selected frequency.
7. Adjust L1 by rotating the tuning slug to bring the oscillator frequency within the phase-lock capture range.
NOTE: L1 is at maximum inductance when the tuning slug is flush with the top of the coil housing.
8. Adjust L1 for a voltmeter reading of 5.0 volts. The lock indicator LED, DSI, should be lit at this time if a high impedance voltmeter is used. If a 20,000 ohm/volt VOM is used, it will be necessary to remove the test lead from test point TP4 before the lock indication LED will be lit. Because stray

signals present on the voltmeter leads may affect the spectral purity of the oscillator, the voltmeter should not be left attached to TP4 during normal transmitter operation.

NOTE: With large variations in ambient temperature, some variations in the TP4 error voltage will be noted, with the voltage increasing gradually with increasing temperature. This does not indicate a change in frequency, and is permissible within the range of 2.0 volts to 7.0 volts. This should be sufficient to handle temperature variations of -60°F (-51°C) to $+122^{\circ}\text{F}$ ($+50^{\circ}\text{C}$) from an initial setup temperature of 77°F ($+25^{\circ}\text{C}$). Readjustment of the error voltage to 5.0 volts after arrival of the transmitter at the final ambient temperature is recommended to allow the greatest tolerance to temperature and component variation.

9. Set the switch on the Recycle PWB to CONT. Set the switch on the Auto Shutdown PWB to OFF.
10. Adjust the RF DRIVE on the AM Oscillator PWB for a reading of approximately 10 watts.
NOTE: If the filter is badly out of adjustment, it may be impossible to get an RF output reading until Step 11 is performed.
11. Adjust the inductor L1 on the AM Oscillator PWB for maximum output. If there is a large increase in RF power, decrease RF level with the RF DRIVE control in order to keep the power level at approximately 10 watts.

SS-800AVS

Southern Avionics
Company

SYNTHESIZER BANDS

FREQUENCY BAND	RF OUTPUT FILTER	AM OSCILLATOR PWB 59	SYNTHESIZER PROGRAMMING BOARD, PWB 129 (NOTE 1)	SYNTHESIZER BOARD, PWB 128
190-250 KHz	190-340 KHz	190-250 KHz	190-250 KHz	ALL BANDS
250-340 KHz		250-340 KHz	240-340 KHz	
340-500 KHz	340-500 KHz	340-500 KHz	320-415 415-625 KHz	
500-625 KHz	500-625 KHz	500-625 KHz	415-625 KHz	
* 1500-1800 KHz	* 1500-1800 KHz	* 1500-1800 KHz	* 1500-1800 KHz	

*Available only with SS-500HV.

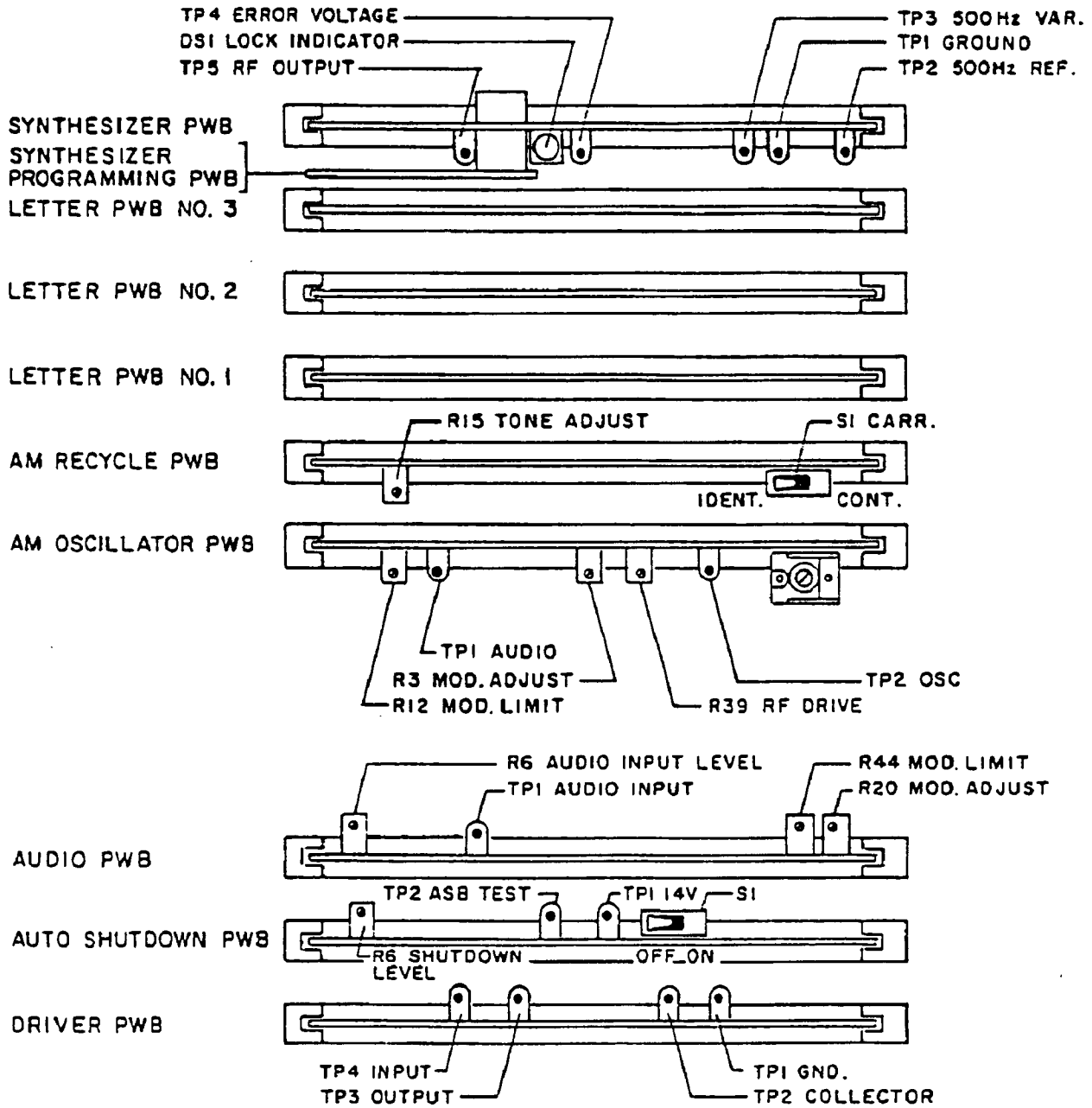

NOTE: 1. THIS DRAWING NO. 2406 REV. B.
2. TITLED: CONTROL AND TESTPOINT POSITIONS.

CONTROL AND TESTPOINT POSITIONS

5.4 Antenna Tune-Up

Install the antenna according to the Antenna Installation manual. See the Transmitter Diagram in section 2 for the location of all transmitter controls.

1. Check that the RF DRIVE control on the Oscillator PWB is fully CCW. Set the switch on the Recycle PWB to CARR. Set the switch on the Auto Shutdown PWB to OFF. Check that the Jumper on TB4 is connected from Terminal 1 to Terminal 3.

NOTE: Autotune is disabled during modulation. If the switch on the Recycle PWB is in CONT (continuous tone), the system will not tune.

2. Apply AC power. The EMITTER VOLTS scale should read 0.1 to 0.2 volts. Note that with a dual system, AC power is applied by placing the Local Radiobeacon Control System power switch in the ON position. The following steps may also be required:
 - a. Press the Primary Transmitter Select switch to the Transmitter 1 position.
 - b. Press the Transmitter On/Off switch to the ON position.
 - c. Press the Reset pushbutton.
3. Slowly turn the RF DRIVE control CW. DO NOT allow the EMITTER VOLTS to go above 0.5. DO NOT allow the TUNE indication to go above half scale. The TUNE indication may momentarily increase if the autotune circuit is tuning the antenna.
4. Check the TUNE indication to determine if the antenna is tuned. The antenna is tuned if the TUNE indication is 0 or very low. Go to Step 7 if the antenna is tuned.
5. Rotate the PC-1000 VERNIER tuning knob from one limit to the other. If the Autotune motor starts to tune the antenna, release the VERNIER knob, and go to Step 7.
6. Turn RF LEVEL control fully CCW, change the FINE TAPS Switch to the next lower tap and repeat Steps 3, 4, and 5. If the antenna still did not tune, change the FINE TAPS Switch to the next higher tap and repeat Steps 3, 4, and 5. Continue this bracketing procedure until the Autotune motor starts to tune the antenna. NOTE: If the FINE TAPS Switch is on tap 4, and it is necessary to decrease the inductance, change the Coarse Tap to the next lower tap and change the FINE TAPS Switch to tap 44. If the FINE TAPS Switch is on tap 44, and it is

necessary to increase the inductance, change the Coarse Tap to the next higher tap and change the FINE TAPS Switch to tap 4. It may be necessary to change the FINE TAPS Switch a few positions before the inductance will be the same as it was before the Coarse Tap was changed.

7. The antenna is properly tuned when the VERNIER tuning knob is in the center of its range or slightly to the left. If the VERNIER tuning knob is not in this position or is at a limit, it will be necessary to change the Fine Tap. CAUTION: Always turn RF LEVEL CCW before changing taps. Increasing the tap number increases the inductance. If the VERNIER tuning knob is at a limit, it may be necessary to change the tap more than once before the VERNIER tuning knob leaves the limit. NOTE: If the FINE TAPS Switch is on tap 4 and it is necessary to decrease the inductance, or if the FINE TAPS Switch is on tap 44 and it is necessary to increase the inductance, see note in Step 6. After each tap change, go back to Step 3.
8. Set the Meter switch on the transmitter to the HI scale and adjust RF DRIVE for a reading of 100W. Switch the meter to TUNE and note the reading. Turn RF DRIVE fully CCW.
9. Increase the IMPEDANCE TRANSFORMER tap in the antenna coupler by one number and adjust RF DRIVE to 100 watts.
10. Check the relative TUNE indication on the meter. If it is greater than the indication noted in Step 8, turn RF DRIVE to full CCW and decrease the IMPEDANCE TRANSFORMER tap to one position lower than the original position. If it is less than the indication noted in Step 8, turn RF DRIVE to full CCW and increase the IMPEDANCE TRANSFORMER tap by one position.
11. Repeat Steps 8, 9, and 10 until the IMPEDANCE TRANSFORMER tap is found that gives the lowest tuning indication. Check the EMITTER VOLTS. Normal reading is 1.3 to 1.7 volts for 100W. If there are several IMPEDANCE TRANSFORMER taps that give a 0 TUNE indication, choose the one that gives a correct EMITTER VOLTS reading.
12. Place the Recycle PWB switch in the IDENT position and adjust R16 (Tol. Adj.) on the coupler Autotune PWB CCW until the Autotune motor begins to chatter. Turn the Tol. Adj. pot CW until all chattering just stops. Remove transmitter power. Remove the clip on the RF output lead. Trim the wire to the proper length insuring that at least 2 inches (5 cm) separates the wire from both the coil and the coupler enclosure. Dress the wire to avoid sharp bends which may lead to high voltage

corona discharge, and solder the wire to the selected coil coarse tap. Install the coil enclosure cover above the coupler control panel.

5.5 Audio Mode Selection

Selection of the various mode options is accomplished by the placement of jumpers on the AM Recycle PWB and by placement of switch S1. Circuit operation is controlled by the voice line input signal through the action of the AGC/Squelch circuit on the Audio PWB. This circuit acts with a fast attack, slow decay characteristic in the presence of a voice line signal.

A standard AM system without the optional voice modulation is programmed for Mode 2. When the optional voice modulation is ordered, Mode 4 is programmed unless otherwise requested.

MODE	DESCRIPTION	TO SELECT
1	Continuous high level voice, no code.	Install Audio PWB. AM Recycle PWB switch S1 on CARR (carrier only).
2	Continuous high level code, no voice.	AM Recycle PWB switch S1 on IDENT. Audio PWB not installed or no line signal applied. Jumpers Ja and Jc installed on AM Recycle PWB. No Jumper Jb installed.
3	Continous high level voice with continous low level code in background.	AM Recycle PWB switch S1 on IDENT. Audio PWB installed. Jumpers Jb and Jc installed on AM Recycle PWB. No Jumper Ja installed.
4	High level voice with low level code in background while voice signal present on audio line. High level code only when voice signal absent.	AM Recycle PWB switch S1 on IDENT. Audio PWB installed. Jumpers Ja and Jc installed on AM Recycle PWB. No Jumper Jb installed. Resistor R19 on the AM Recycle PWB adjusts the low level code modulation percentage.

- 5 High level voice without code signal while voice signal present. High level code only while voice signal absent. AM Recycle PWB switch S1 on IDENT. Audio PWB installed. Jumpers Ja and Jc installed on AM Recycle PWB. No Jumper Jb installed. Resistor R19 removed from the AM Recycle PWB.

5.6 Tone Modulation Adjustment

Tone modulation percentage is factory set using the procedure under the "Frequency and Percent Modulation Adjustment" in section 6. To check modulation or readjust after the system is tuned and operating with the antenna, use an oscilloscope with the probe held in the air to observe the radiated waveform and adjust modulation with R3 on the Oscillator PWB.

5.7 Transmitter Adjustments

5.7.1 Autosutdown and Audio Alignment

Introduction : The following procedures should be performed following the alignment procedures. If voice modulation is not used, skip section "Autosutdown and Audio Alignment," and go directly to section "Autosutdown Adjustment - Nonvoice System."

A. Preliminary:

1. Place the Autosutdown ON/OFF switch S1 in the OFF position. See Autosutdown PWB Schematic and Assembly in Section 2, and the "Control and Test Points Positions" in this section.
2. Measure the audio line level at the input to the transmitter case using a FLUKE 8020B or equivalent digital multimeter. The average level should be -28 dBm (0.031 V_{RMS}) or greater.
3. Set switch S1 on the Audio PWB as follows:
 - a. For high level audio line inputs (-15 dBm to +7 dBm), set to C2 position.
 - b. For low level audio line inputs (-28 dBm to -15 dBm), set to C1 position.
 - c. Set switch S2 on the Audio PWB to ON to activate the audio AGC.
 - d. Check that R6 on the Audio PWB is fully clock-wise. DO NOT ADJUST R20 OR R44.

B. Automatic Shutdown Adjustment:

1. Place the IDENT/CARRIER/CONT switch S1 on the AM Recycle PWB in the CARRIER position.
2. Apply power to the transmitter.
3. Adjust RF power from the transmitter to the desired shutdown level using RF Drive Control R39 on the AM Oscillator PWB.
4. Place the transmitter meter function switch in the 25 DC volts position and connect the test probe furnished with the transmitter between the Probe Jack terminal next to the meter and TP2 on the Autosutdown PWB. See figure, "Control and Testpoints Positions."
5. Rotate R6 and R22 located on the Autosutdown PWB fully CCW.
6. Rotate R6 CW until a downward deflection of the meter is observed.

7. Place the meter function switch in one of the RF watts position and adjust the power output to the desired carrier level.
8. Place the IDENT/CARRIER/CONT switch in the CONT (continuous tone) position.
9. Apply the audio line input signal to the transmitter.
10. Measure the AC_{RMS} voltage at TP1 of the Audio PWB and adjust R6 for an average of 1 V_{RMS} or 3 V_{p-p} .
11. Place the meter function switch in the 25 DC volts position.
12. Rotate Code Tone Shutdown Level Control R22 on the Auto-shutdown PWB CW until the voltage at TP2 of the Autosutdown PWB deflects upward and holds steady.

5.7.2 Autosutdown Adjustment - Nonvoice System

1. Apply power to the transmitter.
2. Adjust RF power from the transmitter to the desired shutdown level using RF Drive Control R39 on the AM Oscillator PWB.
3. Place the transmitter meter function switch in the 25 DC volts position and connect the test probe furnished with the transmitter between the Probe Jack terminal next to the meter and TP2 on the Autosutdown PWB. See figure, "Control and Testpoint Positions."
4. Rotate R6 and R22 located on the Autosutdown PWB fully CCW.
5. Rotate R6 CW until a downward deflection of the meter is observed.
6. Place the meter function switch in one of the RF watts position and adjust the power output to the desired carrier level.
7. Place the IDENT/CARRIER/CONT switch in the IDENT position.
8. Place the meter function switch in the 25 DC volts position. Adjust R22 CW until the meter deflects upward during ident.

5.7.3 Automatic Shutdown Test

To check the automatic shutdown feature for ident failure, place S1 on the Recycle PWB in CONT. After a delay of 15 to 60 seconds, the transmitter will shut down. Reset the system by switching the ON/OFF switch to OFF and then back to ON. To check for the decrease

of power shutdown feature, decrease the power to a level below the desired automatic shutdown level. After a delay of 15 to 60 seconds, the transmitter will shut down. Reset the system and readjust the RF DRIVE for full power. The Automatic Shutdown System will also shut down the transmitter if extreme distortion is present.

5.7.4 Final

Check that S1 on the Recycle PWB is in IDENT and that the ON/OFF Switch on the Auto Shutdown PWB is ON. This completes the tune-up procedure. If the optional Battery Standby System is installed, place the ON/OFF switch in the ON position.

6 MAINTENANCE

6.1 Cautions and Test Equipment List

6.1.1 General Precautions

During operation, extremely high voltages are present at the output of the transmitter, anywhere in the vicinity of the antenna coupler, and on the antenna itself. Carelessness in working around the equipment can result in severe electrical shock.

When working with the equipment, follow standard correct service procedure. Avoid working with the equipment while standing in a wet area forming a good ground. All other applicable safety procedures should be utilized as much as possible.

Transistors may be damaged by careless or improper measuring techniques, particularly when checking resistance. When measuring voltages, insulate all the probe except the tip as a momentary short circuit can destroy a transistor. Use a low wattage soldering iron, as excessive heat can damage semiconductor components.

Use only low wattage irons when working with components mounted on a PWB. Insufficient care or excessive heat in soldering and desoldering can lift component pads, thus destroying a PWB. Use a Solder-Wick or equivalent when desoldering components.

6.1.2 Specific Precautions

When making low level measurements in the transmitter, if possible operate the transmitter into the dummy Load. High level fields associated with the antenna coupler and antenna system may induce substantial signals into the test equipment, seriously compromising the measurements being made.

Many of the transistors and diodes used in an SS-Series radiobeacon are especially chosen for their particular circuit. Even if one of these transistors does cross match to a general replacement type (ECG, HEP, SK, etc.) these replacements MAY NOT substitute and should not be used. Replacement power transistors should be ordered from the factory in order to avoid the possibility of substantial damage to the transmitter.

6.1.3 Test Equipment List

The following equipment is recommended for testing an SS-Series transmitter:

6.1.3.1 Field Service or Checkout

1. VOM, Simpson 260 or equivalent.
2. Oscilloscope, Tektronix 211 or equivalent.
3. Standard electronics-type hand tools.
4. Low wattage soldering iron (25W) with chisel tip.
5. Plastic alignment tools, GC8606 and GC8275.

6.1.3.2 System Alignment and Calibration

1. All of the aforementioned equipment.
2. Frequency counter or meter usable in the transmitter frequency range.

6.2 System Alignment and Calibration

SS-Series radiobeacons do not normally need any adjustment in the way of alignment or calibration. However, if such procedures become necessary, the following alignment procedures must be observed:

6.2.1 AM Oscillator PWB

6.2.1.1 Preliminary

Before making any adjustment to the AM Oscillator, the following preliminary setup should be performed:

1. With AC power removed, disconnect the antenna system and connect the dummy load by transferring the jumper on TB4 from the BNC terminal to the dummy load terminal (see drawing for "Transmitter Diagram").
2. Turn the RF DRIVE control on the AM Oscillator PWB to its full low level (CCW) position.
3. Put Switch S1 on the Recycle PWB in the continuous carrier positionn (CARR).
4. Set the Auto Shutdown PWB switch to OFF.

6.2.1.2 Frequency and Modulation Adjustment

1. Connect an oscilloscope to the dummy load.
2. Remove the RF shield from the transmitter chassis to allow access to the AM and voice modulation circuit PWB's.
3. Adjust the following controls on the AM Oscillator PWB fully CCW.
 - a. Modulation Adjust (R3).
 - b. Modulation Limit (R12).
 - c. RF Drive (R39).

NOTE: These controls are 15 turn pots and possess a slight detent action at the limits of rotation.

4. Adjust the following controls on the Audio PWB (optional) fully CW.
 - a. Audio Input Level.
 - b. Modulation Adjust.

c. Modulation Limit.

5. Remove the AM Oscillator PWB from its connector. Install an Extender PWB in the AM Oscillator PWB connector and install the AM Oscillator PWB in the Extender PWB.
6. Place Recycle PWB switch S1 in the CARR (carrier only) position.
7. Apply AC power to the transmitter. Adjust the RF DRIVE control (R39) CW until the oscilloscope indicates approximately 50 volts p-p across the dummy load.
8. Place Recycle PWB switch S1 in the CONT (continuous tone) position.
9. Adjust the pi-filter inductor (L1) on the AM Oscillator PWB for a maximum RF voltage on the oscilloscope. Caution: Use only a non-ferrous adjustment tool with L1.
10. Adjust the MODULATION ADJUST control (R3) CW for 95% modulation or as desired.

6.2.2 Audio PWB Adjustment

1. Place the IDENT/CARRIER/CONT switch in the CARRIER position.
2. Apply a 1000 Hz tone to the transmitter audio input from an audio oscillator and adjust the audio level using the audio oscillator control and/ or R6 on the Audio PWB for 1 V_{RMS} at TP1 of the Audio PWB.
3. Rotate Modulation Limit Control R44 located on the Audio PWB fully CW to defeat the limiter action.
4. Adjust Voice Modulation Adjust Control R20 located on the Audio PWB CCW until 85% modulation is measured at TB4 terminal 1.
5. Rotate Modulation Limit Control R44 CCW until the modulation percentage is reduced to 80%.

6.2.3 Antenna System Changes

After changing the transmitter frequency, the procedure to follow generally is to repeat the tune-up procedure in the Antenna Tune-Up section. However, if the change involves changing the transmitted frequency from below 415 KHz to above 415 KHz or vice-versa, simply following the tune-up procedure will not work if the Mast Antenna is being used. The SAC Mast Antenna is centerloaded to be resonant at approximately 500 KHz for operation between 200 and 415 KHz and at approximately 900 KHz for operation between 400 KHz and 625 KHz. The resonant frequency of the antenna is chosen by selecting one

of the two lower taps on the center coil. This is accomplished by lowering the antenna and then removing the protective cover from the center section of the antenna. The tap, which allows use of the full coil, sets the resonant frequency at approximately 500 KHz, while the tap allowing use of about one-half of the coil sets the resonant frequency at approximately 900 KHz.

6.2.4 Battery Charger Float Voltage Adjustment

The following procedure is based on a lead calcium storage battery system with 52.4 volts (2.18 volts/cell) chosen as compromise between charging time and battery water use. The following float voltages are recommended by various battery manufacturers. For other batteries consult manufacturers.

Lead Antimony (24 cells)	2.15 to 2.17 volts/cell (51.6 to 52.1) volts
Lead Calcium (24 cells)	2.17 to 2.25 volts/cell (52.1 to 54.0) volts
Nickel Cadmium (38 cells)	1.40 volts/cell (53.2 volts)

As required, adjustment may be made to these values instead of 52.4 volts.

1. Disconnect AC power from the transmitter. Turn off the switch on the battery standby unit and disconnect one terminal wire from the battery bank.
2. Loosen the four retaining screws and remove the battery charger assembly from its enclosure.
3. Position the battery standby unit so that nothing can short to the internal components or wiring of the battery standby unit.
4. Reattach the wire to the battery bank, apply AC power and turn on the switch on the Battery Standby Unit.
5. Measure the battery terminal voltage. If the Float Mode LED on the Charger Control PWB is not lit, allow the batteries to charge fully. The battery voltage should rise to approximately 55 volts. The LED should then light, and the voltage should then fall slowly to approximately 52.4 volts.

6. After the Float Mode LED on the Charger Control PWB becomes lit, allow the battery voltage to stabilize for approximately 15 minutes or until the battery voltage no longer decreases. Rotate R22, the Float Voltage potentiometer located on the Charger Control PWB, to adjust the battery terminal voltage to 52.4 volts. (CCW rotation decreases the float voltage.) NOTE: In a fully charged battery, the terminal voltage may drop very slowly to the normal float voltage. If no change is noted as R22 is rotated, the system is not stabilized.

Allow more time and again try adjusting R22. Changes made to R22 should be made slowly. If R22 is rotated too rapidly, operation may be switched back to current regulating mode and require restabilization. Battery voltage measurements should be made with a digital voltmeter with final float voltage adjustments within ± 0.2 volts of the recommended values.

6.3 Preventive Maintenance

SAC radiobeacons are designed to be electrically maintenance free. Since the equipment is mounted out-of-doors, it is suggested that periodic maintenance be performed to protect the equipment from the environment.

1. Periodically, lubricate the door hinges.
2. Tighten any loose nuts and bolts.
3. With continued exposure to an extreme environment, the fiberglass parts of the antenna system may need to be cleaned and sealed. This is especially true in a salt water or high soot environment which is often encountered on offshore platforms and drilling ships.

6.3.1 Maintenance Log

The following log is offered for ease and completeness of electrical checks. A complete record such as this will be of considerable help in diagnosing trouble in case of equipment failure.

6.4 Corrective Maintenance

6.4.1 Index To Testpoints

This index to testpoints is intended to allow the technician working with the SAC radiobeacon to quickly gain familiarity with the normal voltages and waveforms associated with an SS-Series transmitter.

In addition, whenever possible, an attempt has been made to list some of the abnormal waveforms encountered when troubleshooting an SS-Series NDB and to indicate their probable cause.

INDEX TO TEST POINTS

NOTE: Waveforms are measured with a Tektronix 211 or equivalent; voltages are measured with a Simpson 260 or equivalent. All measurements are made with respect to ground.

CIRCUIT: AM Oscillator PWB Output and Driver PWB Input.

TEST POINT: TP4 (blue) on Driver PWB.

MODE: S1 on Recycle PWB in CONT. Shutdown switch OFF. Full rated power into dummy load or antenna.

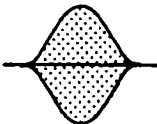
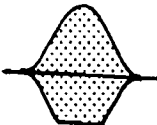
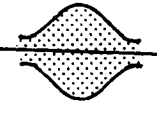
INDICATION	REMARKS	ACTION
Waveforms 	Normal. 100% modulation. Peak-to-peak voltages will vary according to drive requirements of individual transmitters. V_{p-p} up to 25 volts normal.	
	Drive level too high.	Reduce power by turning RF DRIVE control on AM Oscillator PWB CCW.
	Less than 100% modulation.	Adjust R3 on the AM Oscillator PWB for 100% modulation.
DC Voltages + 12 to +14.5 V	Normal.	

CIRCUIT: AM Oscillator PWB Output and Diver PWB Input.

TEST POINT: TP4 (blue) on Driver PWB.



MODE: S1 on Recycle PWB in CONT. Shutdown switch ON. Full rated power into dummy load or antenna.



INDICATION	REMARKS	ACTION
DC Voltages 0 to 0.5 V	Shutdown circuit operating.	Reset shutdown switch. Check shutdown level. Check Modulation

CIRCUIT: Driver Output.

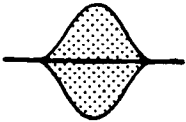
TEST POINT: TP2 (red) on Driver PWB.

MODE: S1 on Recycle PWB in CONT. Shutdown switch OFF. Full rated power into dummy load or antenna.

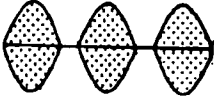
INDICATION	REMARKS	ACTION
DC Voltages +48 to +55 V	Normal.	
0 V	No output from +50 V power supply.	Check AC input voltage. Check circuit breaker in transmitter. If operating from batteries, determine that they are charged and battery standby switch is on.
Waveforms 	Normal. Peak-to-Peak voltages will vary according to drive requirements of individual transmitters. V_{p-p} up to 100 volts normal.	
	Asymmetrical waveform indicates one-half of driver stage not operating or large difference in gain between driver transistors.	Measure voltage across emitter resistor of each transistor; compare. Check AC waveform across emitter resistor.

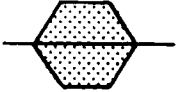
	<p>Distorted waveform indicating cutoff during part of operation.</p>	<p>Check TP4 waveform. Check biasing diode voltage in driver stage.</p>
	<p>Distortion in envelope indicated by white streaks in envelope.</p>	<p>Check for over-driving (waveform becomes clean when drive is reduced).</p>
	<p>Envelope squared indicates saturation of driver transistors due to excessive drive level, de-tuned antenna system, open in driver output transformer, etc.</p>	<p>Check final stage and antenna system for improper tuning or impedance matching. Reduce drive from AM Oscillator PWB until waveform is not distorted, then test final stage.</p>

CIRCUIT: Input to Final.

TEST POINT: TP3 (yellow) on Driver PWB.

MODE: S1 on Recycle PWB in CONT. Shutdown switch OFF. Full rated power into dummy load or antenna.

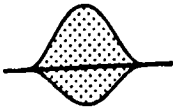
INDICATION	REMARKS	ACTION
DC Voltages +0.6 V \pm 0.2 V	Normal. Bias voltage to final.	
0 V	Bias diodes to final shorted. Fuse to final blown.	Remove AC power. Check forward and reverse resistance between TP3 and TP1 to check bias diodes to final.
+50 V	Final bias diodes open. Final emitter resistors open. Final transistors shorted or open.	Remove AC power. Check final components.
Waveforms 	Normal. Peak-to-peak voltage may vary with individual dual transmitters.	

CIRCUIT: Driver Current.

TEST POINT: Driver PWB emitter resistor.

MODE: S1 on Recycle PWB in CONT. Shutdown switch OFF. Full rated power into dummy load or antenna.

INDICATION	REMARKS	ACTION
DC Voltages 0.2 V	Normal.	
+50 V	Emitter resistor open. Driver transistors open or shorted.	Check driver stage.
Waveforms 	Normal. Peak voltages may vary according to individual transmitters.	

CIRCUIT: Final Amplifier Emitter Current.

TEST POINT: Each final emitter resistor.

MODE: S1 on Recycle PWB in CONT. Shutdown switch OFF. RF DRIVE control on AM Oscillator PWB CCW.

INDICATION	REMARKS	ACTION
DC Voltages 0.2 V	Normal.	
0 V	Bias diodes shorted. Final transistors shorted or open. Fuse in final blown.	Check Final components.

CIRCUIT: Final Amplifier Emitter Current.

TEST POINT: Each final emitter resistor.



MODE: S1 on Recycle PWB in CONT. Shutdown switch OFF. Full rated power into dummy load or antenna.

INDICATION	REMARKS	ACTION
DC Voltages 0.6 to 0.8 V 0.9 to 1.2 V 1.3 to 1.7 V 0.5 to 0.7 V	Normal. SS-250CV SS-500V SS-800AV SS-500HV	
Waveforms 	Normal. Voltage peak is approximately three times VDC.	

CIRCUIT: Final Amplifier Collector Voltage.

TEST POINT: Each final collector (case).

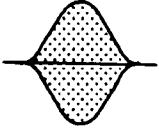
MODE: S1 on Recycle PWB in CONT. Shutdown switch OFF. Full rated power into dummy load or antenna.

INDICATION	REMARKS	ACTION
DC Voltages +50 V	Normal.	
Waveforms 	Normal. Peak-to-peak voltage as much as 100 volts.	
	Saturation. Too much drive, untuned antenna system.	Reduce drive, perform tune-up procedure.
	One side of push-pull amplifier circuit out. Final transistors not properly matched.	Check final amplifier circuitry.

CIRCUIT: Auto Shutdown PWB.

TEST POINT: TP2 (yellow) on Auto Shutdown PWB.

MODE: Keyed modulation. S1 on Recycle PWB in IDENT. Shutdown switch ON. Full rated power into dummy load or antenna. 100% modulation.

INDICATION	REMARKS	ACTION
DC Voltages Voltage at TP2 pulsates during ident from 0 to 1-2.5 V during keying. Transmitter output remains normal.	Normal.	
0 V	No Keying in output circuit, malfunction Q2 through Q5, etc. R6 Auto Shutdown PWB level adjustment alignment improper.	Check transmitter output for keying. Perform resistance voltage measurements on circuit concerned.

CIRCUIT: Auto Shutdown PWB.

TEST POINT: TP2 (yellow) on Auto Shutdown PWB.

MODE: Shutdown switch OFF.

INDICATION	REMARKS	ACTION
Transmitter returns to normal output (without keying) form previous test.	Normal.	
DC Voltages TP Voltage drops to 0 but transmitter does not shutdown after 15 to 60 seconds delay.	Circuit malfunction Q6, Q7, Q8. Switch S1 defective.	Check auto shutdown circuit.

CIRCUIT: Auto Shutdown PWB.

TEST POINT: TP2 (yellow) on Auto Shutdown PWB.

MODE: S1 on Recycle PWB in CARR. Shutdown switch ON. Full rated power into dummy load or antenna.

INDICATION	REMARKS	ACTION
Transmitter output current drops from normal current to 0 current suddenly after 15 to 60 second delay.	Normal.	

CIRCUIT: Auto Shutdown PWB. (+14 V regulated supply).

TEST POINT: TP1 (blue) on Auto Shutdown PWB.

MODE: AC power applied (or 48 VDC applied if operating from batteries).

INDICATION	REMARKS	ACTION
DC Voltages +12.0 to 14.5 V	Normal.	
Less than +12.0 V.	Zener diode circuit probably defective.	Check components CR1 to CR4.
Greater than 16 V.	Q1 regulator transistor probably defective.	Check voltage regulator circuit.

CIRCUIT: Electronic Keyer (Recycle and Letter PWB).

TEST POINT: Pin 1 of all Keyer PWB's. ○

MODE: AC power applied.

INDICATION	REMARKS	ACTION
DC Voltages +12.0 to 14.5 V	Normal.	
Less than +12 or greater than 16 V.	Trouble lies with Auto Shutdown PWB or Keyer PWB.	Check Auto Shutdown PWB regulator circuit first, then check for shorted Keyer PWB.

CIRCUIT: Electronic Keyer (Recycle and Letter PWB).

TEST POINT: Pin 17 Recycle PWB.

MODE: AC power applied. S1 on Recycle PWB in CONT.

INDICATION	REMARKS	ACTION
DC Voltages 0 V	Normal.	

CIRCUIT: Electronic Keyer (Recycle and Letter PWB).

TEST POINT: Pin 17 Recycle PWB.

MODE: AC power applied. S1 on Recycle PWB in IDENT.

INDICATION	REMARKS	ACTION
DC Voltages Fluctuation between) V and approximately 12 V at code rate of 7 w.p.m.	Normal.	
0 V steady.	Steady keying tone present.	Check Q1 and Q2. Check S1. Check for Defective Letter PWB.
12 V steady.	No keying tone.	Check same as above. Check Q3 and Q4.

7 PARTS LIST

Parts are listed by assembly. It is important that the entire reference designator and the part description be used when ordering parts. The serial number of the unit should also be included in any parts order.

PARTS LIST - SS-800AVS

REF.DES.	DESCRIPTION	PART NO.
1	TRANSMITTER ASSEMBLY SS-800AVS	SS-800AVS
C1	CAP, 6500uF, 75VDC, ELCTLT	FAH 6500-75-BE
C2	SAME AS C1	
C3	CAP, 1uF, 200VDC, MYLAR	MMW-2W1
C4	SAME AS C3	
C5	CAP, 0.01uF, 1KV, 190-340 KHz CAP, 0.0068uF, 2KV, 340-500 KHz CAP, 0.004uF, 2KV, 500-625 KHz	27110B103J00 DM19-682J 27120B402J00
C6	SAME AS C5	
CB1	CIRCUIT BREAKER, 6 AMP	44-100-P10
CR1	DIODE, SILICON	1N1203R
CR2	SAME AS CR1	
CR3	DIODE, SILICON	1N4004
CR4	DIODE, TRANZSORB, SILICON	1N5658A
CR5	SAME AS CR4	
CR6	SAME AS CR3	
CR7	SAME AS CR4	
CR8	SAME AS CR4	
E1	LINE SURGE VOLTAGE PROTECTOR	TLP175B
E2	SIGNAL CIRCUIT PROTECTOR (OPT'L)	300C
F1	FUSE, 8 AMP	312-008
F2	FUSE, 3 AMP	312-003
F3-F5	SAME AS F2	
J1	RECEPTACLE: 120 VAC 240 VAC	16301 S-331-BR
J2	PROBE JACK	1458-102
J3	CONN, BNC	31-236
J4-12	CONN, 22-PIN, CARDEDGE	006022022940002

L1	INDUCTOR: 18T, 20uH, 190-340 KHz 14T, 13.5uH, 340-500 KHz 11T, 9uH, 500-625 KHz	2384 2383 2382
M1	METER, 0-1 mA	72 T SSCP
P1	PWR CORD PLUG: 120 VAC 240 VAC	K-5146 K-1443
P2	PWR SWITCH SUPPLY PLUG	PWRSWSUPPLUGSSC
P3	SSC BTRY STANDBY RECEPTACLE	SSCBATTSBYRECP
P4	PWR SWITCH EMITTER PLUG SS-800	PWRSWEMTRPLUG80
Q1*	XSTR, NPN, SILICON	2N567288
Q2-Q4	SAME AS Q1	
	*NOTE: Q1 THROUGH Q4 MUST BE BETA MATCHED. PLEASE SPECIFY BETA DESIRED WHEN ORDERING.	
R1	RES, 300 OHM, 5W, 10%, WW	4604
R2	RES, 27 OHM, 1/2W, 10%, CC	OE2701
R3	NOT USED	
R4	RES, 2 OHM, 5W, 5%, NI, WW	453E1R05
R5	RES, 39 OHM, 1W, 10%, CC	OG3901
R6	NOT USED	
R7	SAME AS R2	
R8	SAME AS R4	
R9	SAME AS R5	
R10	RES, 1K OHM, 11W, 10%, WW	4823
R11	SAME AS R10	
R12	SAME AS R2	
R13	NOT USED	
R14	SAME AS R4	
R15	SAME AS R5	
R16	NOT USED	
R17	SAME AS R2	

R18	SAME AS R4	
R19	SAME AS R5	
R20	RES, 25 OHM, 50W, NI	TM50WC
R21	RES, 1500 OHM, 2W, 10%, CC	OH1521
R22	SAME AS R20	
T1	XFMR, PWR, 110/220V PRIMARY, 80V C.T. SECONDARY	7440
T2	XFMR, FINAL STAGE OUTPUT	DWG 650
T3	XFMR, ASB SENSING	DWG 439
TB1	CONN, TERM BLOCK, 6-POS	6-542
TB2	CONN, TERM BLOCK, 8-POS	8-140
TB3	CONN, TERM BLOCK, 2-POS	2-140
TB4	CONN, TERM BLOCK, 3-POS	3-140
TB5	SAME AS TB4	
A1	AM OSCILLATOR PWB ASSY	PWB-59-2953-(BAND)
A2	AM RECYCLE PWB ASSY	PWB-60-3002
A3	LETTER PWB ASSY OR	PWB-28-189 (LETTER)
	NUMBER PWB ASSY	PWB-40-297 (NUMBER)
A4	SAME AS 1A3	
A5	SAME AS 1A3	
A6	NOT USED	
A7	DRIVER PWB ASSY	PWB-222-4109
A8	AM AUTOSHUTDOWN PWB ASSY	PWB-221-2329
A9	NOT USED	
A10	POWER SWITCH PWB ASSY	PWB-162-1477
A11	METER PWB ASSY	PWB-123-1473
A12	BATTERY STANDBY ASSY (OPT'L)	BATT S/B SSC R2
A1	SSC BATTERY REGULATOR	PWB-167-954
A13	AUDIO PWB ASSY (OPT'L)	PWB-214-2063

A14	NOT USED	
A15	SYNTHESIZER PWB ASSY	PWB-128-652 PWB-128-653-(BAND)
A16	RESET SSC PWB ASSEMBLY	PWB-246-3309
2	ANTENNA COUPLER	PC-1000B

OSCILLATOR PWB-59-2953-(BAND) ASSEMBLY

REF.DES.	PART NUMBER	DESCRIPTION
C2	196D685X9025J	CAP 6.8μF 25V TANT
C3	192P1049R8	CAP .1μF 80V FLM
C4	192P4739R8	CAP .047μF 80V FLM
C5	196D685X9025J	CAP 6.8μF 25V TANT
C6	192P1039R8	CAP .01μF 80V FLM
C7	DM15-221J	CAP 220pF 500V DSM
C8	196D474X9035H	CAP .47μF 35V TANT
C9	196D685X9025J	CAP 6.8μF 25V TANT
C10	404	CAP 8-60pF TRMR
C13	196D685X9025J	CAP 6.8μF 25V TANT
C14	CS13BF105K	CAP 1μF 35V TANT
C15	196D685X9025J	CAP 6.8μF 25V TANT
C16	DM15-501J	CAP 500pF 500V DSM
C17	192P1039R8	CAP .01μF 80V FLM
C20	192P1039R8	CAP .01μF 80V FLM
C21	196D685X9025J	CAP 6.8μF 25V TANT
CR1-2	1N662	DIODE SWITCH 80V .040A
Q1-2	2N3711	XSTR NPN 30V .03A
Q3	2N2222	XSTR NPN 40V .8A
R2	OC4731	RES 47K .25W 10% CC
R3	3006P-1-103	POT 10K .75W CERMET
R4	OC1041	RES 100K .25W 10% CC
R5-6	OC3331	RES 33K .25W 10% CC
R7	OC1031	RES 10K .25W 10% CC
R8	OC3931	RES 39K .25W 10% CC
R9	OC1041	RES 100K .25W 10% CC
R10	OC2731	RES 27K .25W 10% CC
R11	OC1041	RES 100K .25W 10% CC
R12	3006P-1-103	POT 10K .75W CERMET
R13-14	OC1041	RES 100K .25W 10% CC
R15	OC1031	RES 10K .25W 10% CC
R16	OC2221	RES 2.2K .25W 10% CC
R17	OC1021	RES 1K .25W 10% CC
R18-19	OC1011	RES 100 OHM .25W 10% CC
R20	OC1021	RES 1K .25W 10% CC
R21	OC8211	RES 820 OHM .25W 10% CC
R22	OC1521	RES 1.5K .25W 10% CC
R23	OC1021	RES 1K .25W 10% CC
R24-25	OC4721	RES 4.7K .25W 10% CC
R26	OC1031	RES 10K .25W 10% CC

R27	OC3321	RES 3.3K .25W 10% CC
R28	OC1021	RES 1K .25W 10% CC
R29	OC3331	RES 33K .25W 10% CC
R30	OC2221	RES 2.2K .25W 10% CC
R31	OC1041	RES 100K .25W 10% CC
R32	OC1031	RES 10K .25W 10% CC
R33	OC4701	RES 47 OHM .25W 10% CC
R34	OC3321	RES 3.3K .25W 10% CC
R35	OC3331	RES 33K .25W 10% CC
R36	OC6821	RES 6.8K .25W 10% CC
R37	OC2721	RES 2.7K .25W 10% CC
R38	OC3911	RES 390 OHM .25W 10% CC
R39	3006P-1-103	POT 10K .75W CERMET
R40	OC1041	RES 100K .25W 10% CC
R41	OC1031	RES 10K .25W 10% CC
R42	OC4701	RES 47 OHM .25W 10% CC
R43	OC1031	RES 10K .25W 10% CC
R44	OC3321	RES 3.3K .25W 10% CC
TP1	325-107	TESTPOINT YELLOW
TP2	325-105	TESTPOINT BLUE
U1	LM324N	IC QUAD OP AMP
U2	MC1596L	IC BALANCE MOD-DEM0D

BAND 1: 190-240 KHz

REF.DES.	PART NUMBER	DESCRIPTION
C18	192P3329R8	CAP .0033 μ 80V FLM
C19	192P5629R8	CAP .0056 μ F 80V FLM
L1	9056	INDCTR 120-280 μ H VAR

BAND 2: 240-320 KHz

REF.DES.	PART NUMBER	DESCRIPTION
C18	192P2229R8	CAP .0022 μ F 80V FLM
C19	192P3329R8	CAP .0033 μ F 80V FLM
L1	9056	INDCTR 120-280 μ H VAR

BAND 3: 320-415 HKz

REF.DES.	PART NUMBER	DESCRIPTION
C18	DM15-102J	CAP 1000pF 500V DSM
C19	DM19-202J	CAP 2000pF 1KV DSM
L1	9056	INDCTR 120-280 μ H VAR

BAND 4: 415-625 KHz

REF.DES.	PART NUMBER	DESCRIPTION
C18	DM15-102J	CAP 1000pF 500V DSM
C19	DM19-202J	CAP 2000pF 1KV DSM
L1	9055	INDCTR 60-120 μ H VAR

BAND 5: 1500-1800 KHz

REF.DES.	PART NUMBER	DESCRIPTION
C18	DM15-221J	CAP 220pF 500V DSM
C19	DM15-501J	CAP 500pF 500V DSM
L1	9054	INDCTR 28-60μH VAR

BAND 6: 625-1000 KHz

REF.DES.	PART NUMBER	DESCRIPTION
C18	DM15-681J	CAP 680pF 500V DSM
C19	DM15-102J	CAP 1000pF 500V DSM
L1	9055	INDCTR 60-120μH VAR

BAND 7: 500-850 KHz

REF.DES.	PART NUMBER	DESCRIPTION
C18	DM15-471J	CAP 470pF 1KV DSM
C19	DM15-681J	CAP 680pF 500V DSM
L1	9055	INDCTR 60-120μH VAR

AM RECYCLE PWB-60-3002 ASSEMBLY

REF.DES.	PART NUMBER	DESCRIPTION
C1	196D685X9025J	CAP 6.8μF 25V TANT
C2	196D105X9035H	CAP 1μF 35V TANT
C3	196D105X9035H	CAP 1μF 35V TANT
C4	196D685X9025J	CAP 6.8μF 25V TANT
C5	192P1039R8	CAP .01μF 80V FLM
C6	192P1039R8	CAP .01μF 80V FLM
C7	CSR13D686KL	CAP 68μF 15V TANT
C8	TGS10	CAP .01μF 100V CER
C9	NOT USED	
C10	192P1039R8	CAP .01μF 80V FLM
C11-19	NOT USED	
C20	192P1039R8	CAP .01μF 80V FLM
CR1	1N662	DIO SWITCH 80V .040A
L1	CM1869	LAMP 14 MA 10 V CHICAGO MINTR
Q1	2N3711	XSTR NPN 30V .03A
Q2	2N3711	XSTR NPN 30V .03A
Q3	2N2646	XSTR UJT 30V .05A TO18
Q4	2N3711	XSTR NPN 30V .03A
R1	OC2241	RES 220K .25W 10% CC
R2	OC1031	RES 10K .25W 10% CC
R3	OC4721	RES 4.7K .25W 10% CC
R4	OC1541	RES 150K .25W 10% CC
R5	OC2741	RES 270K .25W 10% CC
R6	OC1021	RES 1K .25W 10% CC
R7	OC1031	RES 10K .25W 10% CC
R8	OC1051	RES 1 MEG .25W 10% CC
R9	OC2731	RES 27K .25W 10% CC
R10	OC1031	RES 10K .25W 10% CC
R11	OC3331	RES 33K .25W 10% CC
R12	OC3331	RES 33K .25W 10% CC
R13	OC3321	RES 3.3K .25W 10% CC
R14	OC3331	RES 33K .25W 10% CC
R15	3006P-1-103	POT 10K .75W CERMET
R16	OC1231	RES 12K .25W 10% CC
R17	OC1531	RES 15K .25W 10% CC
R18	OC1211	RES 120 OHM .25W 10% CC
R19	OC1841	RES 180K .25W 10% CC
R20	OC1041	RES 100K .25W 10% CC
R21	OC1041	RES 100K .25W 10% CC
R22	OC1041	RES 100K .25W 10% CC
R23	OC1041	RES 100K .25W 10% CC
R24	OC4731	RES 47K .25W 10% CC

R25	OC1031	RES 10K .25W 10% CC
R26	OC4731	RES 47K .25W 10% CC
S1	SF6TBX392	SWITCH 3 POS PC MOUNT T8206
U1	LM307N	IC OP AMP LM307N
U2	CD4066BE	IC QUAD BI

LETTER PWB-28-189 ASSEMBLY

REF.DES.	PART NUMBER	DESCRIPTION
C1-8	MMW-1W1	CAP 1 μ F 250V POLY
CR1-4	1N662	DIODE SWITCH 80V .040A
Q1-8	2N3711	XSTR NPN 30V .03A
R1	OE2241	RES 220K .5W 10% CC
R2	OE4741	RES 470K .5W 10% CC
R3	OE2731	RES 27K .5W 10% CC
R4	OE2241	RES 220K .5W 10% CC
R5	OE1031	RES 10K .5W 10% CC
R6	OE2731	RES 27K .5W 10% CC
R7	OE1031	RES 10K .5W 10% CC
R8	OE2241	RES 220K .5W 10% CC
R9	OE4741	RES 470K .5W 10% CC
R10	OE2731	RES 27K .5W 10% CC
R11	OE2241	RES 220K .5W 10% CC
R12	OE1031	RES 10K .5W 10% CC
R13	OE2731	RES 27K .5W 10% CC
R14	OE1031	RES 10K .5W 10% CC
R15	OE2241	RES 220K .5W 10% CC
R16	OE4741	RES 470K .5W 10% CC
R17	NOT USED	
R18	OE2241	RES 220K .5W 10% CC
R19	OE1031	RES 10K .5W 10% CC
R20	NOT USED	
R21	OE1031	RES 10K .5W 10% CC
R22	OE2241	RES 220K .5W 10% CC
R23	OE4741	RES 470K .5W 10% CC
R24	NOT USED	
R25	OE1051	RES 1 MEG .5W 10% CC
R26	OE1031	RES 10K .5W 10% CC
R27	NOT USED	
R28	OE1031	RES 10K .5W 10% CC
R29	OE1041	RES 100K .5W 10% CC

NUMBER PWB-40-297 ASSY

REF.DES.	PART NUMBER	DESCRIPTION
C1	P4521	CAP .047μF 50V FLM
C2	MMW-1W1	CAP 1μF 250V POLY
C3-4	P4537	CAP 1μF 50V FLM
C5-6	196D685X9025J	CAP 6.8μF 25V TANT
CR1	1N4743A	DIODE ZENER 13V 1W
CR2-4	1N4004	DIODE RECT 400V 1A
CR5-7	1N662	DIODE SWITCH 80V .040A
CR8-9	1N4004	DIODE RECT 400V 1A
Q1	2N5062	SCR .8 AMP 200V
Q2	2N3711	XSTR NPN 30V .03A
Q3	2N3702	XSTR PNP 25V .2A
R1	OE2721	RES 2.7K .5W 10% CC
R2	OC1031	RES 10K .25W 10% CC
R3-6	OC1041	RES 100K .25W 10% CC
R7	OC1021	RES 1K .25W 10% CC
R8-10	OC1031	RES 10K .25W 10% CC
R11	OC1551	RES 1.5 MEG .25W 10% CC
R12	OC8241	RES 820 K 1/4 W 10% CC
R13	OC1041	RES 100K .25W 10% CC
R14-15	OC1031	RES 10K .25W 10% CC
R16	OC1041	RES 100K .25W 10% CC
R17	OC1031	RES 10K .25W 10% CC
R18	OC2221	RES 2.2K .25W 10% CC
S1	10KB010	SW SPST DIP KEYBOARD
TB1	929835-11-1	CONN HEADER RIGHT-ANGLE
U1	CD4011AE	IC QUAD 2-INPUT NAND
U2	CD4060BE	IC 14 STAGE BINARY COUNTER
U3	CD4078BE	IC 8-INPUT NOR
W1	1563/1-0	WIRE 20/1 1C SOL PVC 0
W2	1563/1-3	WIRE 20/1 1C SOL PVC 3
W3	1563/1-4	WIRE 20/1 1C SOL PVC 4

DRIVER PWB-222-4109 ASSY

REF.DES.	PART NUMBER	DESCRIPTION
C1	MMW-1W1	CAP 1 μ F 250V POLY
CR1-2	1N4004	DIODE RECT 400V 1A
Q1-2	2N6474	XSTR NPN 120V 4AMP
R1	OG4721	RES 4.7K 1W 10% CC
R2-3	OE47G1	RES 4.7 OHM .5W 10% CC
R4	OG4721	RES 4.7K 1W 10% CC
R5	OG6801	RES 68 OHM 1W 10% CC
RT1	2D904	THERMISTOR 10 OHM
T1	DWG 2523	ASY XFMR
T2	DWG 2535	ASY XFMR
TP1	325-103	TESTPOINT BLACK
TP2	325-102	TESTPOINT RED
TP3	325-107	TESTPOINT YELLOW
TP4	325-105	TESTPOINT BLUE
XQ1-2	6072-B	HTSK 6072-B
XRT1	HIX-3/4-0	HTSHRK TBG 3/4 IRR FLEX PL

AUTOSHUTDOWN PWB-221-2329 ASSEMBLY

REF.DES.	PART NUMBER	DESCRIPTION
C1	192P3329R8	CAP .0033 μ F 80V FLM
C2	TGS10	CAP .01 μ F 100V CER
C3	196D105X9035H	CAP 1 μ F 35V TANT
C4	196D104X9035HA1	CAP .1 μ F 35V TANT
C5	196D685X9025J	CAP 6.8 μ F 25V TANT
C6	500D107G025DD7	CAP 100 μ F 25V ELCTLT
C7	196D336X9025P	CAP 33 μ F 25V TANT
C9	196D105X9035H	CAP 1 μ F 35V TANT
CR1	1N4743A	DIODE ZENER 13V 1W
CR2-11	1N662	DIODE SWITCH 80V .040A
K1	W107DIP-3	RELAY 12VDC SPST
Q1	2N2270	XSTR NPN 45V 1A
Q2	2N3711	XSTR NPN 30V .03A
Q3	2N2646	XSTR UJT 30V .050A
Q4	2N2270	XSTR NPN 45V 1A
Q5	2N5062	SCR .8 AMP 200V
R1	OE2221	RES 2.2K .5W 10% CC
R2	OH1521	RES 1.5K 2W 10% CC
R3	4425	RES 1.2K 3.25W 10% WW
R4	OC2221	RES 2.2K .25W 10% CC
R5	OE5621	RES 5.6K .5W 10% CC
R6	3006P-1-503	POT 50K .75W CERMET
R7-8	OC1041	RES 100K .25W 10% CC
R10	OC2721	RES 2.7K .25W 10% CC
R11	OC1031	RES 10K .25W 10% CC
R12	OC2731	RES 27K .25W 10% CC
R13	OC1241	RES 120K .25W 10% CC
R14	OC2711	RES 270 OHM .25W 10% CC
R15	OC1011	RES 100 OHM .25W 10% CC
R15	OC4701	RES 47 OHM .25W 10% CC
R16-17	OC2731	RES 27K .25W 10% CC
R19	OG4721	RES 4.7K 1W 10% CC
R20	OC1031	RES 10K .25W 10% CC
R21	OC4741	RES 470K .25W 10% CC
R22	3006P-1-504	POT 500K .75W CERMET
R23	OC4731	RES 47K .25W 10% CC
R24	OC1031	RES 10K .25W 10% CC
R26	OC4741	RES 470K .25W 10% CC
R27	OC2241	RES 220K .25W 10% CC
R30	OC1821	RES 1.8K .25W 10% CC
R31	OC3331	RES 33K .25W 10% CC
R32	OC8211	RES 820 OHM .25W 10% CC

S1	SF6TCX392	SWITCH 2 POS PC MOUNT T820
TP1	325-105	TESTPOINT BLUE
TP2	325-107	TESTPOINT YELLOW
U1	LM324N	IC QUAD OP AMP
U2	CD4066BE	IC QUAD BILATERAL SWITCH
XQ1	1136B	HTSK TO5 CASE BLACK SQUARE
XQ1A	77175N	INS PAD XSTR
XQA	477175N	INS PAD XSTR

POWER SWITCH PWB-162-1477 ASSY

REF.DES.	PART NUMBER	DESCRIPTION
C1	196D104X9035HA1	CAP .1μF 35V TANT
C2-5	NOT USED	
C6-9	5GAD10	CAP .001μF 1KV CER
C10	196D685X9025J	CAP 6.8μF 25V TANT
C11	196D336X9025P	CAP 33μF 25V TANT
C12	196D105X9035H	CAP 1μF 35V TANT
CR1-2	1N4733A	DIODE ZENER 5.1V 1W
CR3-7	1N4004	DIODE RECT 400V 1A
CR8-11	NOT USED	
CR12-13	1N4004	DIODE RECT 400V 1A
DS1	MV5753	DIODE LIGHT EMITTING RED
Q1-2	2N5415	XSTR PNP 200V 1A
Q3	2N6475	XSTR 2N6475
Q4,5	NOT USED	
Q6-8	2N3440	XSTR NPN 250V 1A
Q9	MCR70-3	SCR MCR70-3
R1-2	45JR10	RES .1 OHM 5W
R3	NCF25-680	RES 680 OHM .25W 5% C.F.
R4	NCF25-270	RES 270 OHM .25W 5% C.F.
R5	NCF50-2.2K	RES 2.2K .5W 5% C.F.
R6-9	NCF25-10K	RES 10K .25W 5% CARBONFILM
R10-13	NOT USED	
R14	NCF25-10K	RES 10K .25W 5% CARBONFILM
R15	NCF25-1K	RES 1K .25W 5% CARBONFILM
R16	NCF1W-3.3K	RES 3.3K 1W 5% CARBONFILM
R17	NCF25-2.2K	RES 2.2K .25W 5% CARBONFILM
R18	4411	RES 500 OHM 3.25W 10% WW
R19	NCF25-1K	RES 1K .25W 5% CARBONFILM
R20	NCF25-470	RES 470 OHM .25W 5% C.F.
R21	4430	RES 2K 3.25W 10% WW
R22	4442	RES 5K 3.25W 10% WW
R23	NCF25-15K	RES 15K .25W 5% CARBONFILM
R24	3006P-1-103	POT 10K .75W CERMET
R25-27	NCF25-10K	RES 10K .25W 5% CARBONFILM
R28	NCF25-2.7M	RES 2.7MEG .25W 5PCTCARBONFIL
R29-30	NCF25-1K	RES 1K .25W 5% CARBONFILM
R31	OC1811	RES 180 OHM .25W 10% CC
R32	NCF25-6.8K	RES 6.8K .25W 5% C.F.
R33	NCF25-10K	RES 10K .25W 5% CARBONFILM
RT1	CA31J1	THERMISTOR 1K DISC
U1-3	LM311N	IC HI-PFRM VOLT COMPARATOR
XDS1	909-235	INS MOUNT LED

XQ1-2
XQ3-5
XQ6
XQ7-8

77175N
NOT USED
2228-B
77175N

INS PAD XSTR
HTSK TO 5 CASE ROUND BLACK
INS PAD XSTR

METER PWB-123-1473 ASSY

REF.DES.	PART NUMBER	DESCRIPTION
C1-2	TGS10	CAP .01 μ F 100V CER
C3	192P2249R8	CAP .22 μ F 80V FLM
Q1-2	2N3711	XSTR NPN 30V .03A
R1-2	OE12G1	RES 1.2 OHM .5W 10% CC
R4	OC8231	RES 82K .25W 10% CC
R5	OC1031	RES 10K .25W 10% CC
R6	OC4721	RES 4.7K .25W 10% CC
R7	OC3911	RES 390 OHM .25W 10 % CC
R8	OC1031	RES 10K .25W 10% CC
R9	OC2221	RES 2.2K .25W 10 % CC
R10	3006P-1-502	POT 5K .75W CERMET
R11	OC1021	RES 1K .25W 10% CC
R12	WS15A	RES 2.5K .5W 1% PRECISION
R13	WS15B	RES 25K .5W 1% PRECISION
R14	WS15A	RES 2.5K .5W 1% PRECISION
R15	3006P-1-502	POT 5K .75W CERMET
S1	12-RCB6-J-PC	SW 2POLE PCMT 12POS
T1	DWG 440	ASY XFMR METER

BATTERY STANDBY ASSEMBLY

REF.DES.	PART NUMBER	DESCRIPTION
CR1-14	NOT USED	
CR15	1N1203R	DIO RECT 300V 12A DO4
F1	312-008	FUSE 8 AMP
F2	312-002	FUSE 2 AMP
K1	JA1ATMDC24V	RELAY SPST 24VDC
P1	1-480340-0	HOUSING 6 POS PIN
Q1-7	NOT USED	
Q8	2N3773	XSTR POWER BIPOLAR 140V 16A TO204AA/AE
S1	7561-K4	SWITCH DPST
T1	4-06-6-016	XFMR POWER
XF1	342012 A	FUSE HOLDER
XF2	342012 A	FUSE HOLDER
XQ1-7	NOT USED	
XQ8	6266	SOCKET XSTR MOUNT PORCELAIN
XQA1-7	NOT USED	
XQA8	7403-09FR05	INS SIL PAD T03 GREY
XQB1-7	NOT USED	
XQB8	7004D	COVER TRANSISTOR T03 CASE BLK
XS1	30-5632-4	PLATE ON-OFF SWITCH

SSC BATTERY REGULATOR PWB-167-954 ASSY

REF.DES.	PART NUMBER	DESCRIPTION
C1-2	196D685X9025J	CAP 6.8μF 25V TANT
C3	TGS50	CAP .05μF 100V CER
C4	TGS10	CAP .01μF 100V CER
C5	TGS50	CAP .05μF 100V CER
C6	196D685X9025J	CAP 6.8μF 25V TANT
CR1-4	1N5404	DIODE SILICON 400V 3A
CR5	1N4004	DIODE RECT 400V 1A
CR6	1N4744A	DIODE ZENER 15V 1W
CR7	1N4004	DIODE RECT 400V 1A
CR8-9	1N4733A	DIODE ZENER 5.1V 1W
CR10-11	1N4004	DIODE RECT 400V 1A
CR12	1N5363B	DIODE ZENER 30V 5W
CR13-14	1N4004	DIODE RECT 400V 1A
DS1	MV5753	DIODE LIGHT EMITTING RED
Q1	2N5415	XSTR PNP 200V 1A
Q2	2N6475	XSTR 2N6475
Q3-6	2N3440	XSTR NPN 250V 1A
Q7	2N5415	XSTR PNP 200V 1A
R1	OC1031	RES 10K .25W 10% CC
R2	OC1811	RES 180 OHM .25W 10% CC
R3	OC1021	RES 1K .25W 10% CC
R4	OC1821	RES 1.8K .25W 10% CC
R5	OC1001	RES 10 OHM .25W 10% CC
R6	OC4701	RES 47 OHM .25W 10% CC
R7-8	TS5-0.5	RES .5 OHM 5W 5% NI
R9	OC2221	RES 2.2K .25W 10 % CC
R10-11	OC1031	RES 10K .25W 10% CC
R12	4430	RES 2K 3.25W 10% WW
R13	OC2221	RES 2.2K .25W 10% CC
R14	4430	RES 2K 3.25W 10% WW
R15	OC3311	RES 330 OHM .25W 10% CC
R16	OC8211	RES 820 OHM .25W 10% CC
R17	OC4741	RES 470K .25W 10% CC
R18	OC2251	RES 2.2 MEG .25W 10% CC
R19	OC2241	RES 220K .25W 10% CC
R20	OC5641	RES 560K .25W 10% CC
R21	OC5631	RES 56K .25W 10% CC
R22	3006P-1-103	POT 10K .75W CERMET
R23	OC4721	RES 4.7K .25W 10% CC
R24	OC1521	RES 1.5K .25W 10% CC
R25	OC2721	RES 2.7K .25W 10% CC
R26	OC1521	RES 1.5K .25W 10% CC

R27	OC2231	RES 22K .25W 10% CC
R28	OC4721	RES 4.7K .25W 10% CC
R29	4411	RES 500 OHM 3.25W 10% WW
RT1-2	2D904	THERMISTOR 10 OHM
U1	LM324N	IC QUAD OP AMP
U2	4N32	IC OPTO ISLR NPN DARL 30V 050A
U3	CD4001BE	IC QUAD 2-INPUT NOR
XQ1-7	77175N	INS PAD XSTR

AUDIO PWB-214-2063 ASSEMBLY

REF.DES.	PART NUMBER	DESCRIPTION
C1-2	192P1049R8	CAP .1μF 80V FLM
C3-4	P4521	CAP .047μF 50V FLM
C5-6	196D685X9025J	CAP 6.8μF 25V TANT
C7	P4521	CAP .047μF 50V FLM
C8	192P1049R8	CAP .1μF 80V FLM
C9	196D336X9025P	CAP 33μF 25V TANT
C10	196D685X9025J	CAP 6.8μF 25V TANT
C11	196D474X9035H	CAP .47μF 35V TANT
C12	DM15-151J	CAP 150pF 500V DSM
C13	196D105X9035H	CAP 1μF 35V TANT
C14	P4517	CAP .022μF 50V FLM
C15	DM15-751J	CAP 750pF 500V DSM
C16	P4523	CAP .068μF 50V FLM
C17	500D107G025DD7	CAP 100μF 25V ELCTLT
C18	196D685X9025J	CAP 6.8μF 25V TANT
C19	196D105X9035H	CAP 1μF 35V TANT
C21	196D685X9025J	CAP 6.8μF 25V TANT
C22	CSR13D686KL	CAP 6.8μF 15V TANT
C23-25	P4513	CAP .01μF 50V FLM
C26	DM15-221J	CAP 220pF 500V DSM
C27-30	196D685X9025J	CAP 6.8μF 25V TANT
CR1-8	1N4004	DIODE RECT 400V 1A
Q1	2N5462	XSTR P-CHAN FET (ECG326-SYL)
Q2-3	2N3711	XSTR NPN 30V .03A
R1	OC6811	RES 680 OHM .25W 10% CC
R2	OC6821	RES 6.8K .25W 10% CC
R3	OC1041	RES 100K .25W 10% CC
R4	OC2241	RES 220K .25W 10% CC
R5	OC4711	RES 470 OHM .25W 10% CC
R6	3006P-1-103	POT 10K .75W CERMET
R7	OC1531	RES 15K .25W 10% CC
R8	OC3341	RES 330K .25W 10% CC
R9	OC5631	RES 56K .25W 10% CC
R10-12	OC1041	RES 100K .25W 10% CC
R13	OC8221	RES 8.2K .25W 10% CC
R14-15	OC1041	RES 100K .25W 10% CC
R16	OC1541	RES 150K .25W 10% CC
R17	OC2251	RES 2.2 MEG .25W 10% CC
R18	OC2231	RES 22K .25W 10% CC
R19	OC2731	RES 27K .25W 10% CC

R20	3006P-1-103	POT 10K .75W CERMET
R21	OC6821	RES 6.8K .25W 10% CC
R22	OC1011	RES 100 OHM .25W 10% CC
R23	OC3341	RES 330K .25W 10% CC
R24	OC1031	RES 10K .25W 10% CC
R26	OC1531	RES 15K .25W 10% CC
R27	OC1041	RES 100K .25W 10% CC
R28	OC1011	RES 100 OHM .25W 10% CC
R29	OC1031	RES 10K .25W 10% CC
R30	OC1041	RES 100K .25W 10% CC
R31	OC1031	RES 10K .25W 10% CC
R32-33	OC4731	RES 47K .25W 10% CC
R34-35	OC4741	RES 470K .25W 10% CC
R36	OC1061	RES 10 MEG .25W 10% CC
R37	OC6831	RES 68K .25W 10% CC
R38	OC2241	RES 220K .25W 10% CC
R39	OC1041	RES 100K .25W 10% CC
R40	OC2731	RES 27K .25W 10% CC
R41-42	OC1041	RES 100K .25W 10% CC
R43	OC3331	RES 33K .25W 10% CC
R44	3006P-1-103	POT 10K .75W CERMET
R45	OC1041	RES 100K .25W 10% CC
R46	OC3331	RES 33K .25W 10% CC
R47-48	OC4711	RES 470 OHM .25W 10% CC
R49	OC1511	RES 150 OHM .25W 10% CC
RR25	OC1021	RES 1K .25W 10% CC
RT1	CA31J1	THERMISTER 1K DISC
RT2	CA31J1	THERMISTER 1K DISC
S1	76SD01S	SWITCH 2 POS DPDT DIP SEALED
S2	240002GP	SWITCH 2 POS MINI-DIP SEALED
T1	SP70	TRANSFORMER TRIAD
TP1	325-108	TESTPOINT BROWN
U1	LM324N	IC QUAD OP AMP
U2	LM324N	IC QUAD OP AMP
U3	CD4066BE	IC QUAD BILATERAL SWITCH
XT1	SP-310	SHIELD TRANSFORMER TRIADSP31

DRIVER PWB-222-4109 ASSY

REF.DES.	PART NUMBER	DESCRIPTION
C1	MMW-1W1	CAP 1 μ F 250V POLY
CR1-2	1N4004	DIODE RECT 400V 1A
Q1-2	2N6474	XSTR NPN 120V 4AMP
R1	OG4721	RES 4.7K 1W 10% CC
R2-3	OE47G1	RES 4.7 OHM .5W 10% CC
R4	OG4721	RES 4.7K 1W 10% CC
R5	OG6801	RES 68 OHM 1W 10% CC
RT1	2D904	THERMISTOR 10 OHM
T1	DWG 2523	ASY XFMR
T2	DWG 2535	ASY XFMR
TP1	325-103	TESTPOINT BLACK
TP2	325-102	TESTPOINT RED
TP3	325-107	TESTPOINT YELLOW
TP4	325-105	TESTPOINT BLUE
XQ1-2	6072-B	HTSK 6072-B
XRT1	HIX-3/4-0	HTSHRK TBG 3/4 IRR FLEX PL

SYNTHESIZER PWB-128-652 ASSEMBLY

REF.DES.	PART NUMBER	DESCRIPTION
C1-3	196D105X9035H	CAP 1 μ F 35V TANT
C4	TGS50	CAP .05 μ F 100V CER
C5	196D474X9035H	CAP .47 μ F 35V TANT
C6	TGS50	CAP .05 μ F 100V CER
C7	NOT USED	
C8	404	CAP 8-60pF TRMR
C9	CD15ED330J	CAP 33pF 500V DSM
C10	196D336X9025P	CAP 33 μ F 25V TANT
C11	196D105X9035H	CAP 1 μ F 35V TANT
CR1	MV2112	DIODE TUNING MV2112
CR2	1N960B	DIODE ZENER 9.1V .5W
DS1	MV5753	DIODE LIGHT EMITTING RED
J1	716AG2D-SP	CONN SKT SNGL PIN SILPLD
JXS1-4	716AG2D-SP	CONN SKT SNGL PIN SILPLD
Q1-2	2N3711	XSTR NPN 30V .03A
Q3-4	2N3702	XSTR PNP 25V .2A
R1	OC3931	RES 39K .25W 10% CC
R2	OC2721	RES 2.7K .25W 10% CC
R3	OC1031	RES 10K .25W 10% CC
R4	OC1521	RES 1.5K .25W 10% CC
R5	OC5601	RES 56 OHM .25W 10% CC
R6	OC1021	RES 1K .25W 10% CC
R7	OC1541	RES 150K .25W 10% CC
R8	OC2231	RES 22K .25W 10% CC
R9	OC8221	RES 8.2K .25W 10% CC
R10	OC2261	RES 22 MEG .25W 10% CC
R11	OC3911	RES 390 OHM .25W 10% CC
R12	OE1211	RES 120 OHM .5W 10% CC
R13	OC4741	RES 470K .25W 10% CC
R14	OC5611	RES 560 OHM .25W 10% CC
R15	OC2231	RES 22K .25W 10% CC
R16	OC1001	RES 10 OHM .25W 10% CC
S1-3	330002GS	SWITCH 10 POS MICRO-DIP SLD
S4	240002GP	SWITCH 2 POS MINI-DIP SEALED
TP1	325-103	TESTPOINT BLACK
TP2	325-102	TESTPOINT RED
TP3	325-106	TESTPOINT ORANGE
TP4	325-107	TESTPOINT YELLOW
TP5	325-104	TESTPOINT GREEN
U1-2	CD4060BE	IC 14 STAGE BINARY COUNTER
U3	CD4059AE	IC COUNTER PROG DIVIDE-BY-N
U4-5	4308R-101-224	RES 220K NETWORK

W1	8020	WIRE 20 SOL TND COP
XDS1	909-235	INS MOUNT LED
Y1	CRYSTAL 2048.00	CRYSTAL 30pF SC-7 2048.00KHZ

SYNTHESIZER PROGRAMMING PWB-129-653 ASSEMBLY

REF.DES. PART NUMBER DESCRIPTION

C1 SEE CHART
 C2 SEE CHART
 C3 SEE CHART
 C4 SEE CHART
 C5 SEE CHART
 L1 SEE CHART
 P1 641-AG1

CONN PLUG 14PIN ADAPTER

F (kHz)	C1	C2	C3	C4	C5	L1
190-250	2000pF	---	2000pF	2000pF	500pF	.65-1.3mH
240-340	2000pF	---	2000pF	2000pF	500pF	280-650 μ H
320-415	2000pF	300pF	2000pF	2000pF	250pF	120-280 μ H
415-625	2000pF	470pF	2000pF	2000pF	250pF	60-120 μ H
500-800	1000pF	300pF	1000pF	1000pF	250pF	60-120 μ H
800-1250	1000pF	150pF	1000pF	1000pF	250pF	20-60 μ H
1.5-1.8MH Z	1000pF	---	1000pF	500pF	100pF	28-60 μ H

RESET SSC PWB-246-3309 ASSY

REF.DES.	PART NUMBER	DESCRIPTION
C1	P4521	CAP .047μF 50V FLM
C2	MMW-1W1	CAP 1μF 250V POLY
C3-4	P4537	CAP 1μF 50V FLM
C5-6	196D685X9025J	CAP 6.8μF 25V TANT
CR1	1N4743A	DIODE ZENER 13V 1W
CR2-4	1N4004	DIODE RECT 400V 1A
CR5-7	1N662	DIODE SWITCH 80V .040A
CR8-9	1N4004	DIODE RECT 400V 1A
Q1	2N5062	SCR .8 AMP 200V
Q2	2N3711	XSTR NPN 30V .03A
Q3	2N3702	XSTR PNP 25V .2A
R1	OE2721	RES 2.7K .5W 10% CC
R2	OC1031	RES 10K .25W 10% CC
R3-6	OC1041	RES 100K .25W 10% CC
R7	OC1021	RES 1K .25W 10% CC
R8-10	OC1031	RES 10K .25W 10% CC
R11	OC1551	RES 1.5 MEG .25W 10% CC
R12	OC8241	RES 820 K 1/4 W 10% CC
R13	OC1041	RES 100K .25W 10% CC
R14-15	OC1031	RES 10K .25W 10% CC
R16	OC1041	RES 100K .25W 10% CC
R17	OC1031	RES 10K .25W 10% CC
R18	OC2221	RES 2.2K .25W 10% CC
S1	10KB010	SW SPST DIP KEYBOARD
TB1	929835-11-1	CONN HEADER RIGHT-ANGLE
U1	CD4011AE	IC QUAD 2-INPUT NAND
U2	CD4060BE	IC 14 STAGE BINARY COUNTER
U3	CD4078BE	IC 8-INPUT NOR
W1	1563/1-0	WIRE 20/1 1C SOL PVC 0
W2	1563/1-3	WIRE 20/1 1C SOL PVC 3
W3	1563/1-4	WIRE 20/1 1C SOL PVC 4

PC-1000B		
REF.DES	DESCRIPTION	PART NUMBER
2	PC-1000B	PC-1000B
B1	MOTOR	22C1120510
C1	CAP 2000pF 500V	DM19-200J
C2	CAP 340-1070pF	307M
C3	CAP 1000pF 500V DSM	DM15-102J
E1	SPARK GAP	DWG 452
F1	FUSE .5 AMP	312-500
J2	CONN 22 PIN	006022022940002
J3	HOUSING 3 POS AMP	1-480303-0
	SOCKET AMP	60617-1
M1	METER	72T 4-8 AMPS
P3	PIN HOUSING 3 POS AMP	1-480303-0
	PIN AMP	60618-1
R1	RES 220 OHM 5W	4600
R2	RES 100 OHM 8W	1516
R3	RES 20 OHM 5W NI	453E2005
R4	NOT USED	
S1,2	SWITCH 11 POS	111-11
T1	TRANSFORMER IMPEDANCE	DWG 455
T2	TRANSFORMER CURRENT	DWG 440
T3	COIL TUNING	DWG 803
T4	TRANSFORMER VSWR SENSE	DWG 438
TB1	TERMINAL BLOCK 4 POS	4-140
A1	ANTENNA/CURRENT TUNING METER PWB	PWB-118-641
A2	AUTOTUNE MOTOR DRIVE PWB	PWB-142-732
A3	LIMIT SWITCH	
CR1-4	DIODE SILICON GI	1N4004
DS1,2	LED	FLV-117

R1,2	RES 560 OHM .25W	OC5611
S1,2	SWITCH MINIATURE CHERRY	E2300A
A4	COUPLER LIGHTNING PROTECTOR	
C1	CAP .01 μ F 1KV MICA	27110B103J00
L1	INDUCTOR 10MH	6306

ANTENNA/CURRENT TUNING METER PWB-118-641

REF.DES.	PART NUMBER	DESCRIPTION
C1	DM15-501J	CAP 500pF 500V DSM
C2	TGS10	CAP .01μF 100V CER
C3	192P2249R8	CAP .22μF 80V FLM
C4	196D685X9025J	CAP 6.8μF 25V TANT
C5	DM15-102J	CAP 1000pF 500V DSM
C6	196D104X9035HA1	CAP .1μF 35V TANT
CR1	1N4733A	DIO ZENER 1W 5.1V DO41
Q1	2N3711	XSTR NPN 30V .03A
Q2	2N3711	XSTR NPN 30V .03A
Q3	2N3711	XSTR NPN 30V .03A
R1	OE12G1	RES 1.2 OHM .5W 10% CC
R2	OE12G1	RES 1.2 OHM .5W 10% CC
R3	OC1821	RES 1.8K .25W 10 % CC
R4	OC8231	RES 82K .25W 10% CC
R5	OC1031	RES 10K .25W 10% CC
R6	OC4721	RES 4.7K .25W 10% CC
R7	OC3911	RES 390 OHM .25W 10% CC
R8	OC1031	RES 10K .25W 10% CC
R9	OC2221	RES 2.2K .25W 10% CC
R10	3006P-1-502	POT 5K .75W CERMET
R11	3006P-1-502	POT 5K .75W CERMET
R12	OC1021	RES 1K .25W 10% CC
R13	OE22G1	RES 2.2 OHM .5W 10% CC
R14	3006P-1-502	POT 5K .75W CERMET
R15	NOT USED	
R16	OC1021	RES 1K .25W 10% CC
S1	SAC3388	DET SWITCH CUTTING

AUTOTUNE MOTOR DRIVE PWB-142-732 ASSY

REF.DES.	PART NUMBER	DESCRIPTION
C1	5GAD10	CAP .001μF 1KV CER
C3-4	196D105X9035H	CAP 1μF 35V TANT
C6	CM05ED101J03	CAP 100pF 500V DSM
C7	P4555	CAP .0022μF 50V FLM
C8	DM15-501J	CAP 500pF 500V DSM
C9	TGS50	CAP .05μF 100V CER
C10	P4559	CAP .0047μF 50V FLM
C11	196D685X9025J	CAP 6.8μF 25V TANT
C12-13	196D104X9035HA1	CAP .1μF 35V TANT
C14	196D336X9025P	CAP 33μF 25V TANT
C15-16	196D105X9035H	CAP 1μF 35V TANT
CR1	1N662	DIODE SWITCH 80V .040A
CR2	1N4743A	DIODE ZENER 13V 1W
CR3-4	1N662	DIODE SWITCH 80V .040A
CR5-6	1N4004	DIODE RECT 400V 1A
CR7-10	1N662	DIODE SWITCH 80V .040A
DS1-3	MV5753	DIODE LIGHT EMITTING RED
Q1-2	2N3711	XSTR NPN 30V .03A
Q3	2N3702	XSTR PNP 25V .2A
Q4-5	2N3711	XSTR NPN 30V .03A
Q6	2N6388	XSTR NPN 80V, 10A
Q7	2N2905A	XSTR PNP 60V .6A
Q8	2N6388	XSTR NPN 80V, 10A
Q9	2N2905A	XSTR PNP 60V .6A
Q10	2N3711	XSTR NPN 30V .03A
Q11	2N6388	XSTR NPN 80V, 10A
Q12	2N2905A	XSTR PNP 60V .6A
R1	OG1041	RES 100K 1W 10% CC
R3	OC1051	RES 1 MEG .25W 10 % CC
R4	OC2221	RES 2.2K .25W 10 % CC
R5	OH2701	RES 27 OHM 2W 10% CC
R6	OC1051	RES 1 MEG .25W 10 % CC
R7	OC2221	RES 2.2K .25W 10 % CC
R8	OC6831	RES 68K .25W 10% CC
R9	OC8221	RES 8.2K .25W 10% CC
R10	OC8201	RES 82 OHM .25W 10% CC
R11	OC1031	RES 10K .25W 10% CC
R12	OC3921	RES 3.9K .25W 10% CC
R13	OC1031	RES 10K .25W 10% CC
R14	OC2241	RES 220K .25W 10 % CC
R15	OC1041	RES 100K .25W 10% CC
R16	3006P-1-103	POT 10K .75W CERMET

R17	OC2241	RES 220K .25W 10 % CC
R18	OC1031	RES 10K .25W 10% CC
R19	OC2231	RES 22K .25W 10 % CC
R20	OC1031	RES 10K .25W 10% CC
R21	OC5611	RES 560 OHM .25W 10% CC
R22	OC1021	RES 1K .25W 10% CC
R23	OC5611	RES 560 OHM .25W 10% CC
R24	OC1021	RES 1K .25W 10% CC
R25	OC5611	RES 560 OHM .25W 10% CC
R26	OC3321	RES 3.3K .25W 10 % CC
R27-30	OC1041	RES 100K .25W 10% CC
R31	OC4721	RES 4.7K .25W 10% CC
R32	OC4721	RES 4.7K .25W 10% CC
S1	SF6TCX392	SWITCH 2 POS PC MOUNT T8201
T1	DWG 95	XFMR T1 PWB61,87,142
TP1	325-108	TESTPOINT BROWN
TP2	325-102	TESTPOINT RED
U1	CD4001BE	IC QUAD 2-INPUT NOR
U2	CD4001BE	IC QUAD 2-INPUT NOR
U3	CD4070BE	IC QUAD EXCL-OR
U4	MM74C74N	IC DUAL-D FLIP-FLOP
U5	LM311N	IC HI-PFRM VOLT COMPARATOR
U6	CD4001BE	IC QUAD 2-INPUT NOR
U7	CD4000BE	IC 3-INPUT DUAL NOR
XDS1-3	909-235	INS MOUNT LED
XQ7-9	77175N	INS PAD XSTR
XQ11	6073-B	HTSK LOW PROFILE 6073-B
XQ11A	4-55-77-9	PAD THERMASIL 4-55-77-9
XQ12	77175N	INS PAD XSTR

PC-1000/3000 (OPTIONAL) POWER SUPPLY PWB-116-529 ASSEMBLY

REF.DES.	PART NUMBER	DESCRIPTION
C1	TC75501B	CAP 500 μ F 75V TUB
CR1	1N4004	DIODE RECT 400V 1A
CR2	1N4004	DIODE RECT 400V 1A
CR3	1N4004	DIODE RECT 400V 1A
CR4	1N4004	DIODE RECT 400V 1A
F1	312-500	FUSE .5 AMP
S1	46206LFR	SWITCH DPDT SLIDE
T1	DPC34-700	XFMR PC MOUNT
TB1	3-142Y	BLOCK 3POS Y TERMINAL
XF1	102068	FUSECLIP PC MT
XF1A	840836	COVER FUSE BLUE
XT1	24BR	BKT F/DPC34-700

8 MODIFICATIONS

OUTPUT FILTER

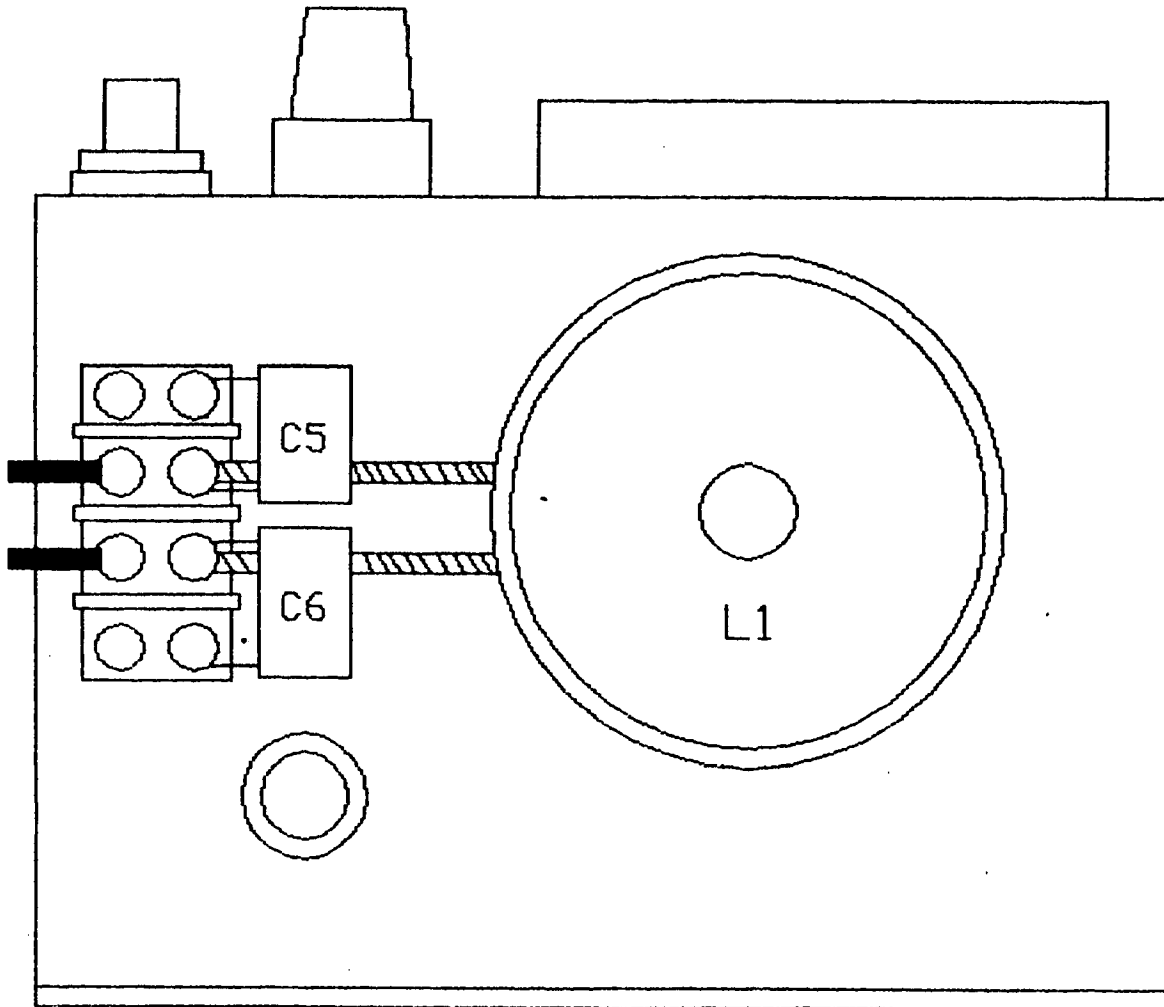

NOTES 1. THIS DWG NO. 4437
2. TITLE: OUTPUT FILTER

CIRCUIT BREAKER 6 AMP PART # 44-100-P10 6AMP, Ref. Des. CB1, IS
REPLACED BY FUSEHOLDER PART # 342012 A, AND FUSE 6.25 AMP PART #
313-6.25